

Energy Absorption
Vibration Control

ADONI TECH

Wire Rope Vibration Isolator

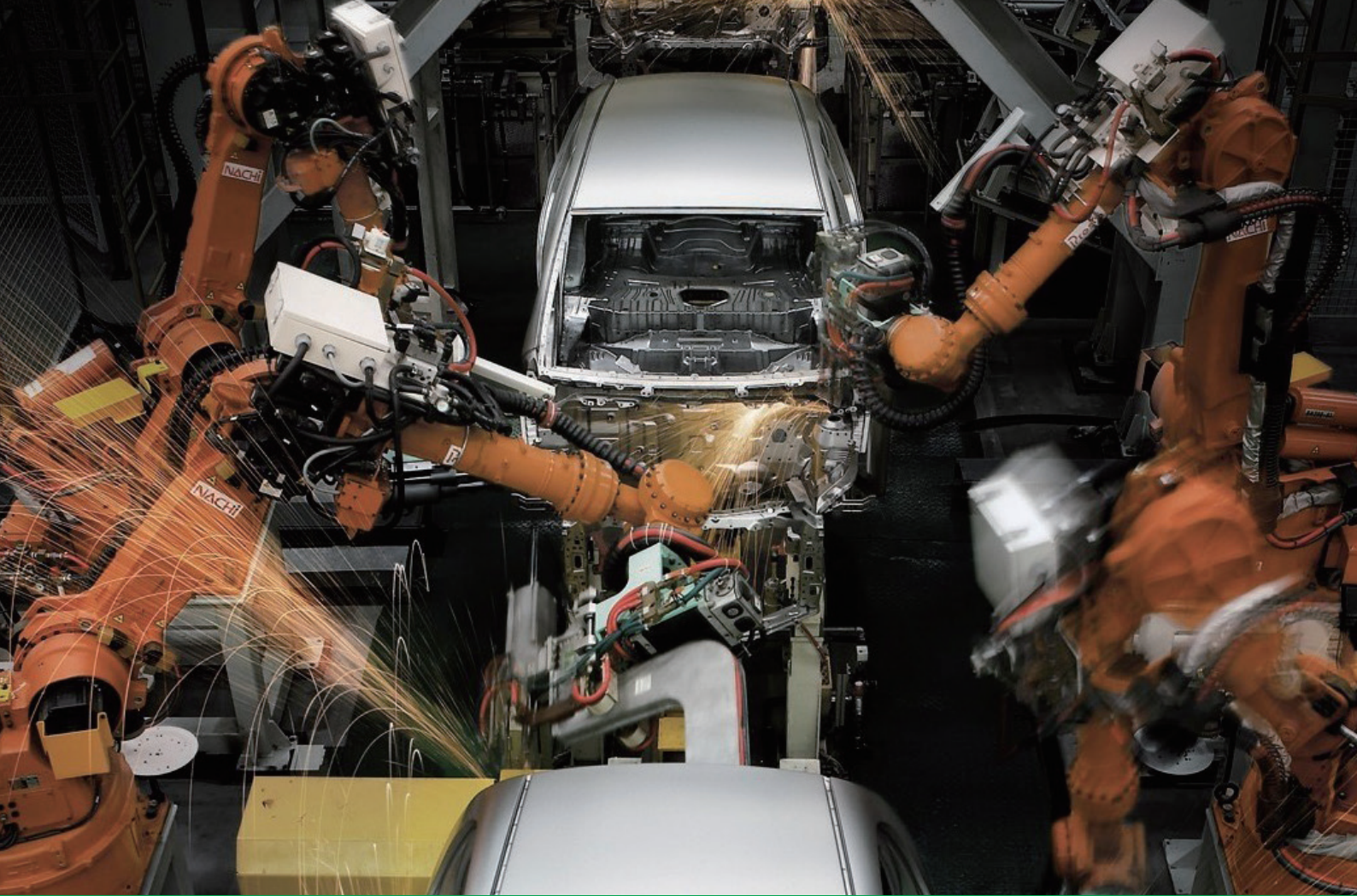



**FOCUSES ON COST-EFFECTIVE ENERGY
ABSORPTION AND VIBRATION ISOLATION
SOLUTIONS.**

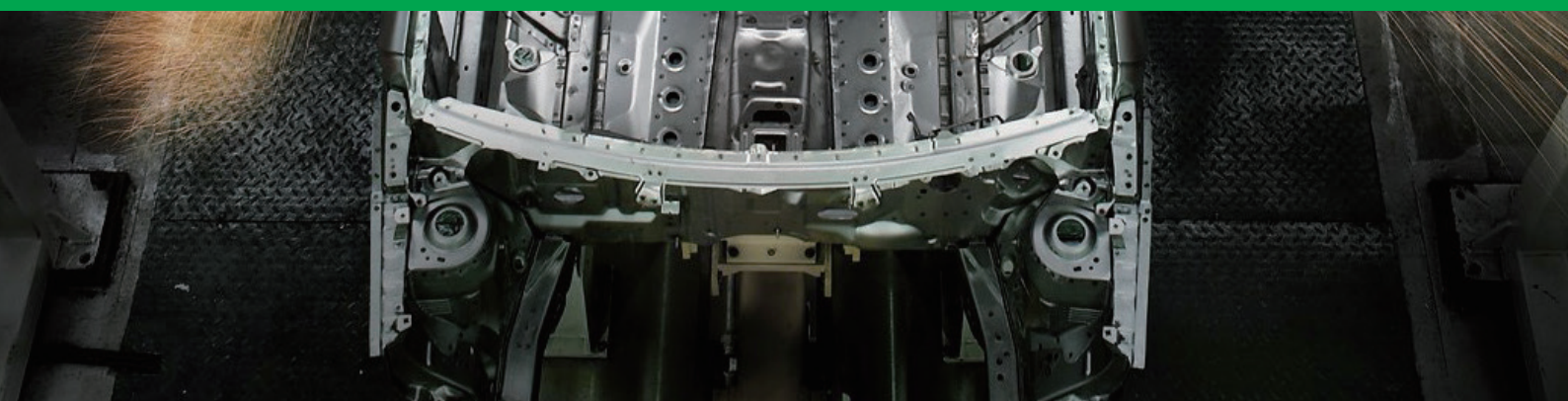

Table of Contents

Brand Profile 3

Wire Rope Vibration Isolators



WR Series Wire Rope Vibration Isolators

Overview, Technical Data4-34

CR Series Compact Wire Rope Vibration Isolators

Overview, Technical Data35-46

A modern building with a glass facade and a white geometric overlay. The building is partially obscured by a large white triangle that points towards the bottom right. The sky is a light, overcast grey. The bottom left corner of the image is a solid green triangle.

**EXCELLENT IN QUALITY
AND VALUE FOR ENERGY
ABSORPTION AND VIBRATION
ISOLATION PRODUCTS**

BRAND PROFILE

and development, manufacture, testing and solutions of energy absorption and

- Leading product design in the world.
- All the key components use top brand products in the industry, more than 60% components are originally from US.
- Standardized assembly process.
- High precision, testing of whole series equipments, testing rate of finished products as high as 100%.

Brand Advantages:

- Excellent working life and performance.
- Prompt product delivery, enough safety inventories.
- Quick and good technical supports such as product sizing, product testing, and solutions.
- On-site service support from domestic professionals within 24 hours.



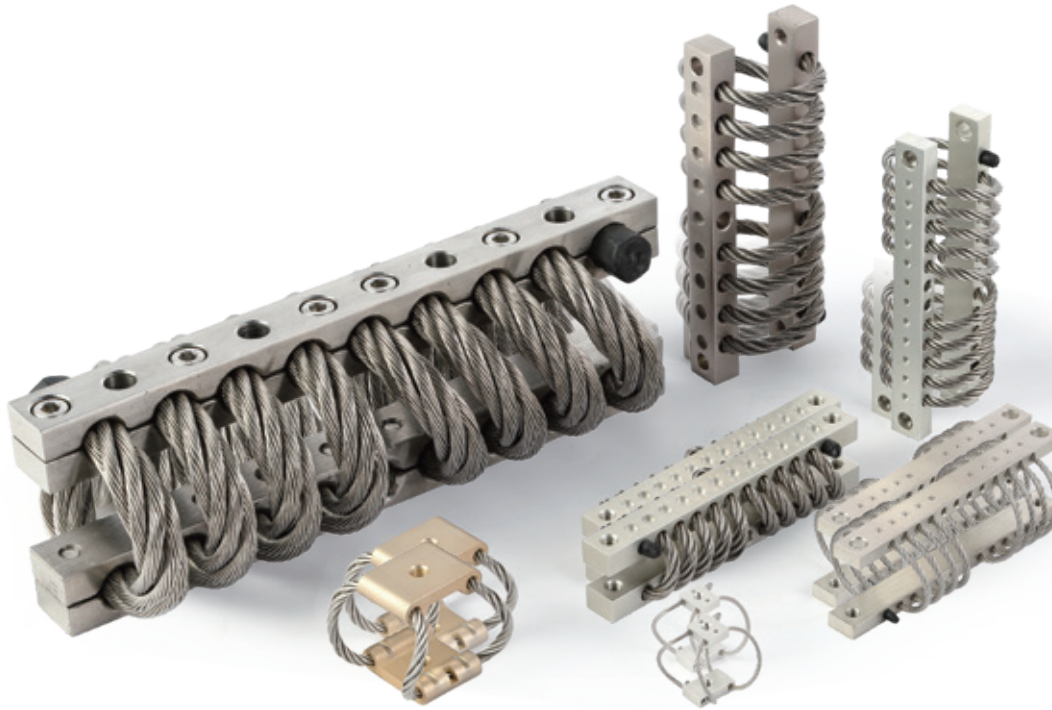

Features and Benefits

Standard Wire Rope Vibration Isolators are comprised of stainless steel stranded cable threaded through aluminum alloy retaining bars that are mounted for effective shock and vibration isolation.

With their corrosion resistant, all metal construction, wire rope vibration isolators are environmentally stable, high-performance shock and vibration isolators that are

unaffected by chemicals, oil, ozone, abrasives and temperature extremes. Specially designed anti-vibration wire rope vibration isolator provides better performance and damping ratio based on clients' requirements, particularly suitable for high bearing capacity requirements and high shock applications. Distortion ratio can be as high as 70-80%. This series products are widely used in civil and military equipments.

Materials and Finishes:

Standard: Wire rope: Stainless steel 302 / 304
 Mount bars: Aluminum alloy surface (Anodized)
 Hardware: Alloy steel, Zinc Plated
 Thread: Stainless Steel Self Clinching Insert(WR2-WR8 Series),
 Threaded Bar(WR12-WR40 Series)

Special: HGGs Series all stainless steel products / HGGN Series anti-vibration high energy vibration isolators

Isolator Options:

Mounting: EKD offers a full range of mounting combinations of thru hole, countersunk and threaded bars.

Loops: EKD's wire rope vibration isolators can be purchased with the full number of loops, or as few as 2 loops. The number of loops is indicated in the isolator part number. Performance is provided for full loop isolators. Performance for reduced loop isolators can be obtained by a simple ratio.

Bellmouth: EKD's wire rope isolators are available with a "bellmouth" option. The bellmouth feature includes mount bars with radii manufactured into the wire rope hole edges. This option is recommended for high fatigue applications. Add an "R" to the end of the part number.

Performance:

Stiffness(KV or KS) :

Wire rope vibration isolators exhibit non-linear stiffness behavior. Small deflections, usually associated with vibration isolation, will have a different spring rate than larger shock deflections. EKD company publishes typical vibration stiffness value(Kv), and average shock stiffness values(Ks) within the catalog. These values can be used with the provided equations listed later to predict system performance. The stiffness values listed in the catalog are for full-loop versions. For reduced loop versions, ratio the stiffness by dividing the number of desired loops by the number of full loops.

Isolator Axes:

Wire Rope Vibration Isolators are multi-axis vibration isolators. The diagram below includes load axis definitions and deflection considerations.

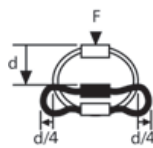

COMPRESSION

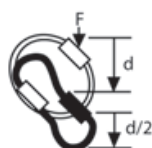

45° COMPRESSION/ ROLL

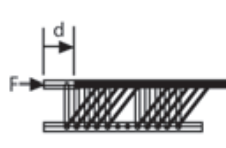

FIXED SHEAR

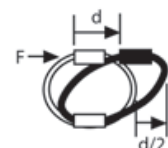

FIXED ROLL

Damping: Typically 5-15%, depending on size and input level. The performance of HGGN Series anti-vibration high energy vibration isolator is significantly improved. For specific damping considerations, please consult EKD company.

Mounting Orientation:

The diagrams below illustrate typical mounting orientations.

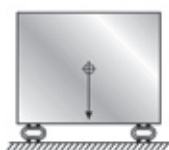

COMPRESSION

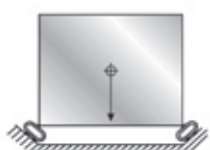

45° COMPRESSION/ ROLL



FIXED SHEAR

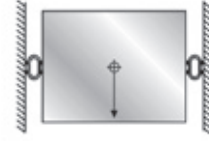

FIXED ROLL

Stabilizer:

Stabilizers are used to control deflections of tall supported masses. Stabilizers are typically recommended when the height equals 2-times the width or depth dimension. In most applications, the quantity of stabilizers required is half as many as the base isolators, and select one size softer than the base isolators. Stabilizers are usually side mounted.

Applications Worksheet		METRIC
<p>PART I SYSTEM DATA</p> <p>1. Total Supported Load(W_T): $W_T = \text{_____ Kg} \times 9.81 = \text{_____ N}$</p> <p>2. Number of Isolators(n): $n = \text{_____}$</p> <p>3. Static Load per Isolator(w): $W = \frac{W_T}{n}$</p> <p>4. Load Axis: Compression Shear/Roll 45° Compression/ Roll</p>		<p>$W = \text{_____ N}^*$ Load Axis</p>
<p>PART II VIBRATION SIZING</p> <p>1. Input Excitation Frequency $(f_i) = \text{_____ Hz} = \left(\frac{\text{rpm}}{60} \right)$</p> <p>2. System Response Natural Frequency for 80% isolation $(f_n) = \frac{(f_i)}{30} = \text{_____ Hz}$</p> <p>3. Maximum Isolator Vibration stiffness(K_v): $K_v = \frac{W (2\pi f_n)^2}{g}$ $g = 9.81 \text{ m/sec}^2$</p> <p>4. Select an isolator by comparing calculated values with technical data for the desired load axis provided in tables for each isolator. a.) Calculated “W” must be less than the isolator's maximum static load. b.) Isolator's vibration stiffness value must be less than the calculated maximum K_v.</p>		<p>$K_v = \text{_____ N/m}$</p>
<p>PART III Shock Sizing:</p> <p>1. Maximum Allowable Transmitted Acceleration: $A_T = \text{_____ G 's}$</p> <p>2. Shock Input Velocity: Free Fall Impact: $V = \sqrt{2gh}$ $g = 9.81 \text{ m/sec}^2$ $h = \text{Drop Height (m)}$</p> <p>3. Minimum Isolator Response Deflection: $D_{min} = \frac{V^2}{g(A_T)}$</p> <p>4. Maximum Isolator Shock Stiffness: $K_s = \frac{W(V/D_{min})^2}{g}$</p> <p>5. Select an isolator by comparing calculated values with technical data for the desired load axis provided in tables for each isolator. a.) Calculated “W” must be less than the isolator's maximum static load. b.) Calculated D_{min} must be less than the isolator's maximum deflection. Note: Metric deflections are calculated in meters(m) and technical data is in millimeters(mm). c.) Isolator's shock stiffness must be less than the calculated maximum “K_s” .</p> <p>6. Check actual deflection using “K_s” from technical data to ensure that the isolator's deflection is not exceeded. $D_{actual} = \frac{V}{\sqrt{\frac{K_s(\text{Isolator})}{W} g}}$</p> <p>7. If isolator's maximum deflection is exceeded, select another isolator and repeat Steps 5 and 6.</p>		<p>$D_{min} = \text{_____ m}$ $K_s = \text{_____ N/m}$</p>

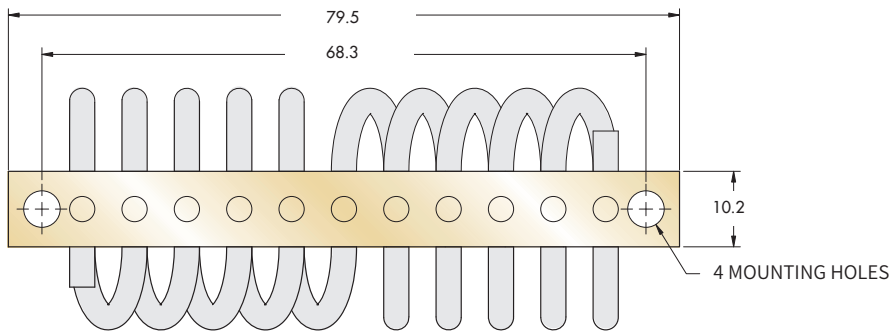

Note: Dimensions are in mm /
Tolerances are $\pm 0.25\text{mm}$

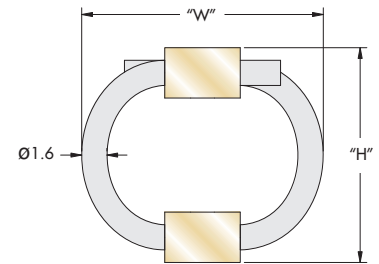
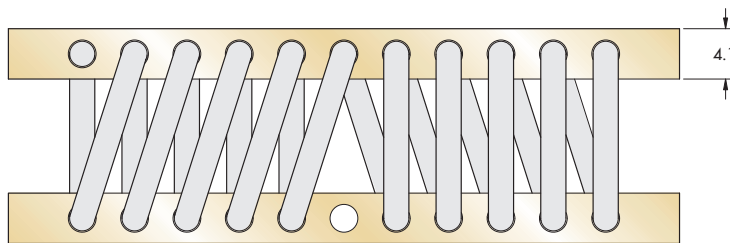

WR

Model	Height ("H") mm	Width (Ref) mm	Unit Weight Kg	Mounting Options	Thru Hole mm	Thread mm	C'Sink Metric
WR2-100	18	25	0.02	B, D, E	$\varnothing 4.7 \pm 0.13$	M4 X 0.7	90°
WR2-200	20	28	0.02	A, B, C, D, E, S			
WR2-400	25	30	0.03				
WR2-600	28	33	0.03				
WR2-700	30	36	0.03				
WR2-800	33	38	0.03				

Ordering Example

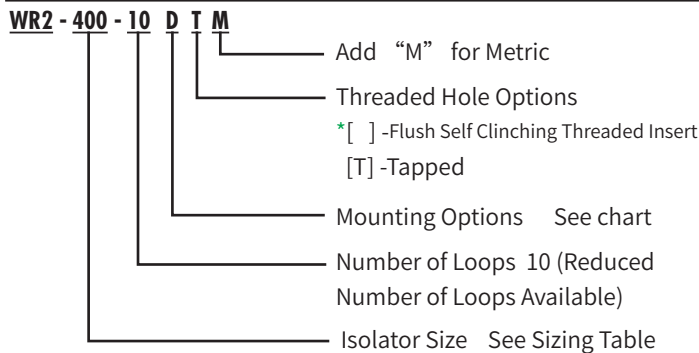

Mounting Options

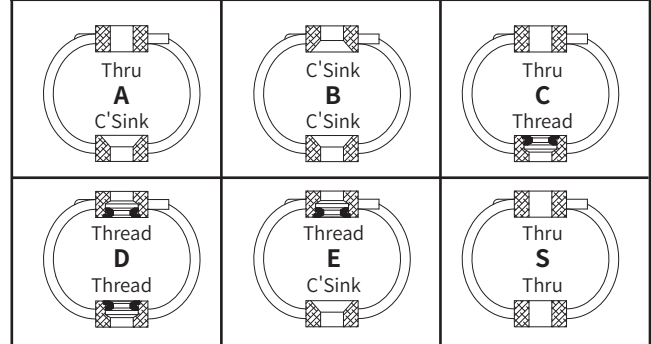

*Standard characteristics. Delivery time may be postponed for non-standard products.

- Maximum recommended torque for standard threaded insert is 0.7 Nm.
- Operating Temperature Range: -100°C~260°C

Static Load vs Deflection

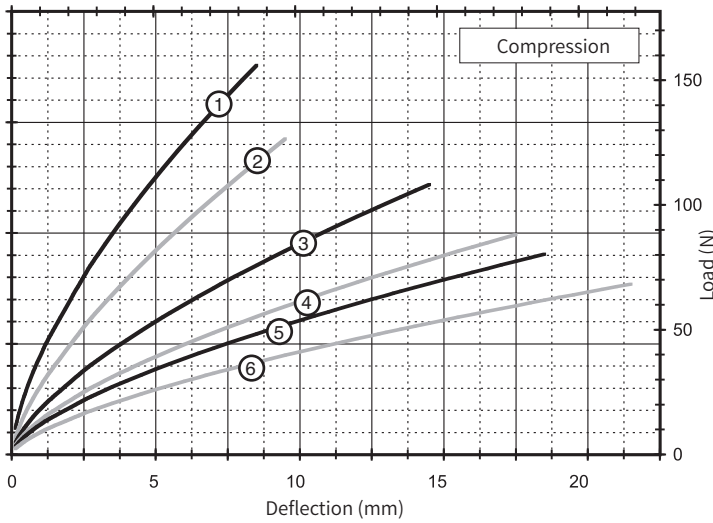

Compression

Curve	Model	Max. Static Load N	Max. Deflection mm	Kv (Vibration) kN/m	Ks (Shock) kN/m
1	WR2-100-10	47	8.6	36	22
2	WR2-200-10	36	9.7	25	16
3	WR2-400-10	31	14.7	17	8.8
4	WR2-600-10	27	17.8	12	6.1
5	WR2-700-10	22	18.8	11	5.3
6	WR2-800-10	20	21.8	7.9	3.9

WR

45° Compression / Roll

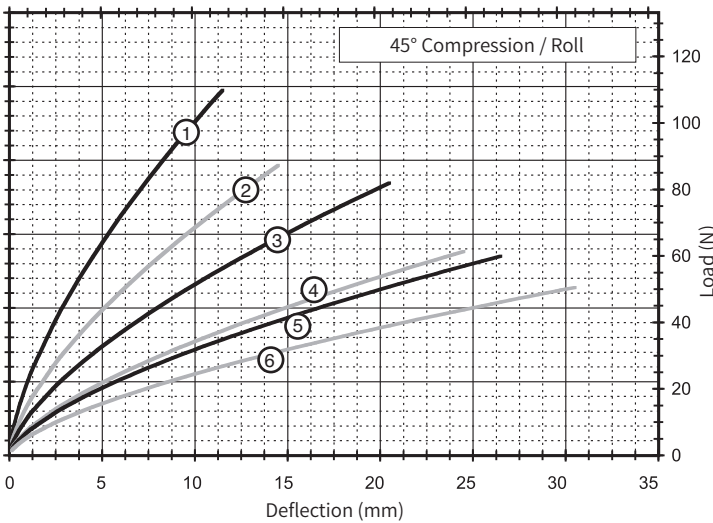

Curve	Model	Max. Static Load N	Max. Deflection mm	Kv (Vibration) kN/m	Ks (Shock) kN/m
1	WR2-100-10	33	11.7	20	11.4
2	WR2-200-10	24	14.7	14	7.0
3	WR2-400-10	24	20.8	11	4.7
4	WR2-600-10	18	24.9	7.0	3.0
5	WR2-700-10	18	26.9	6.1	2.6
6	WR2-800-10	16	31.0	5.3	1.9

Shear/Roll

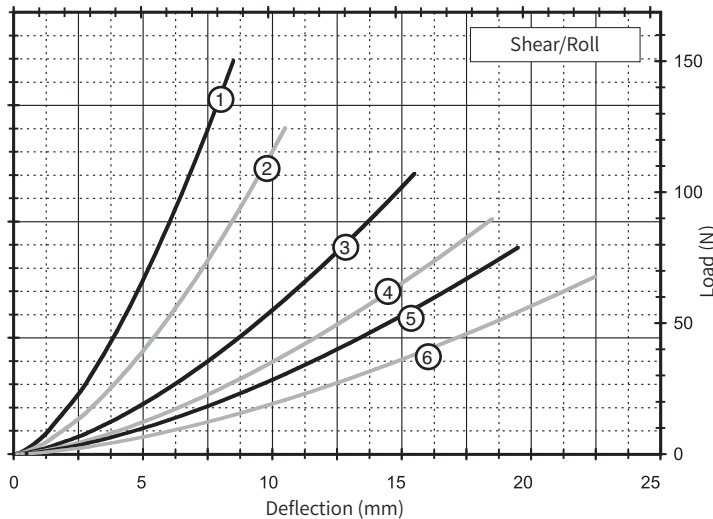

Curve	Model	Max. Static Load N	Max. Deflection mm	Kv (Vibration) kN/m	Ks (Shock) kN/m
1	WR2-100-10	22	8.6	14	14
2	WR2-200-10	18	10.7	8.8	8.8
3	WR2-400-10	16	15.7	5.3	5.3
4	WR2-600-10	13	18.8	3.9	3.9
5	WR2-700-10	13	19.8	3.2	3.2
6	WR2-800-10	11	22.9	2.3	2.3

Note: Performance provided for full loop models with standard (302/304) stainless steel cable. Please consult EKD company for other options. Do not extrapolate curves.

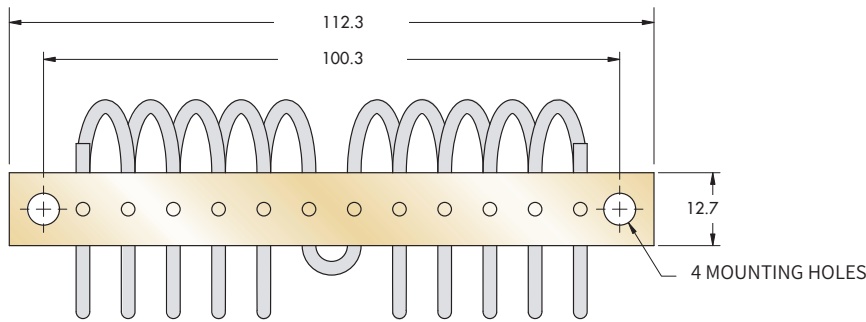

Note: Dimensions are in mm /
Tolerances are $\pm 0.25\text{mm}$

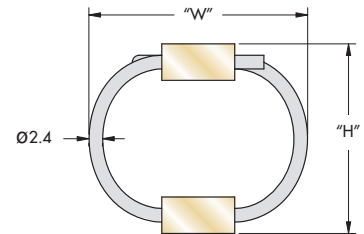
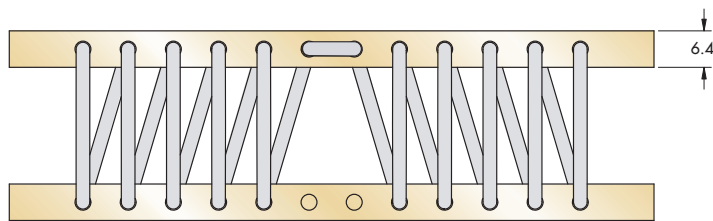

WR

Model	Height ("H") mm	Width (Ref) mm	Unit Weight Kg	Mounting Options	Thru mm	Thread mm	C'Sink Metric
WR3-100	23	28	0.06	B, D, E	$\varnothing 5.6 \pm 0.13$	M5 X 0.8	90°
WR3-200	25	30	0.07	A, B, C, D, E, S			
WR3-400	28	33	0.07				
WR3-600	33	38	0.07				
WR3-700	36	41	0.07				
WR3-800	38	43	0.08				

Ordering Example

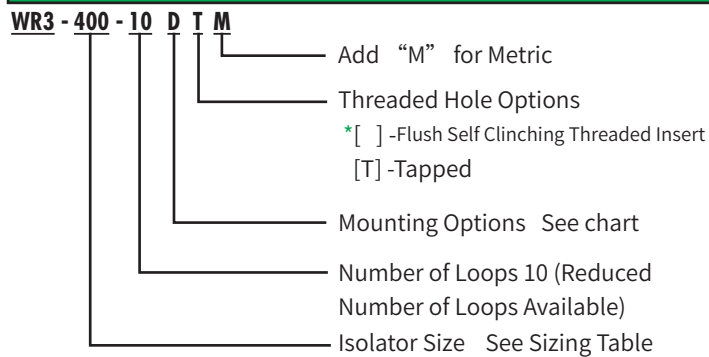

Mounting Options

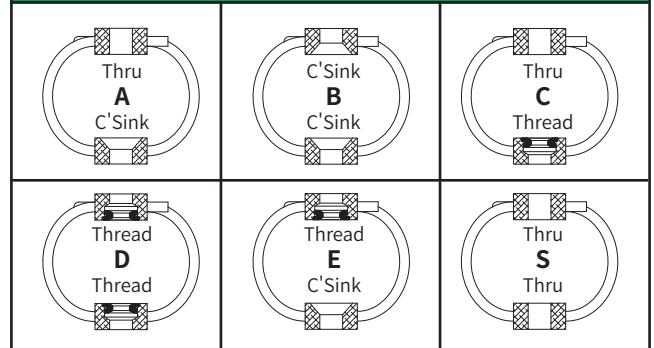

*Standard characteristics. Delivery time may be postponed for non-standard products.

- Maximum recommended torque for standard threaded insert is 0.9 Nm.
- Operating Temperature Range: -100°C~260°C

Static Load vs Deflection

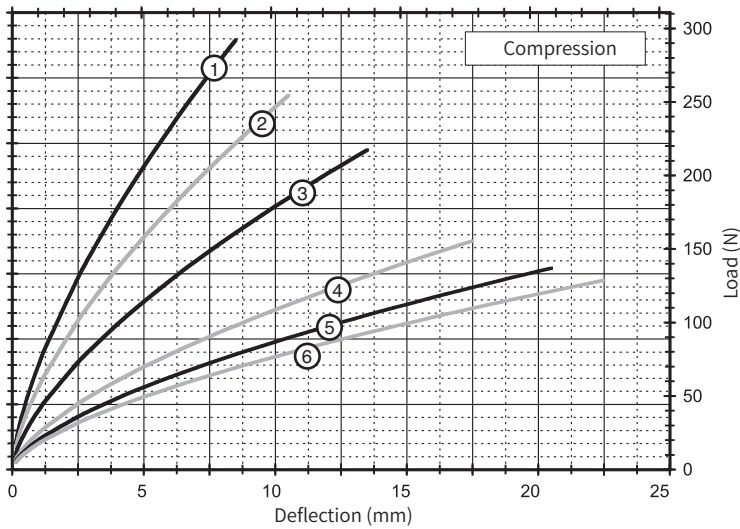

Compression

Curve	Model	Max. Static Load N	Max. Deflection mm	Kv (Vibration) kN/m	Ks (Shock) kN/m
1	WR3-100-10	85	8.6	65	40
2	WR3-200-10	76	10.7	51	30
3	WR3-400-10	62	13.7	37	19
4	WR3-600-10	44	17.8	23	11
5	WR3-700-10	40	20.8	18	7.9
6	WR3-800-10	40	22.9	16	7.0

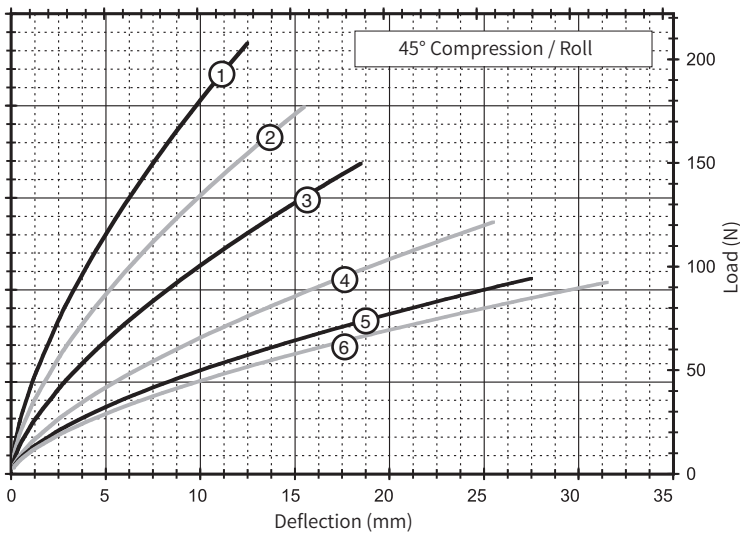

45° Compression / Roll

Curve	Model	Max. Static Load N	Max. Deflection mm	Kv (Vibration) kN/m	Ks (Shock) kN/m
1	WR3-100-10	62	12.7	38	20
2	WR3-200-10	53	15.7	28	14
3	WR3-400-10	44	18.8	21	9.6
4	WR3-600-10	36	25.9	13	5.6
5	WR3-700-10	31	27.9	11	4.4
6	WR3-800-10	27	32.0	9.6	3.5

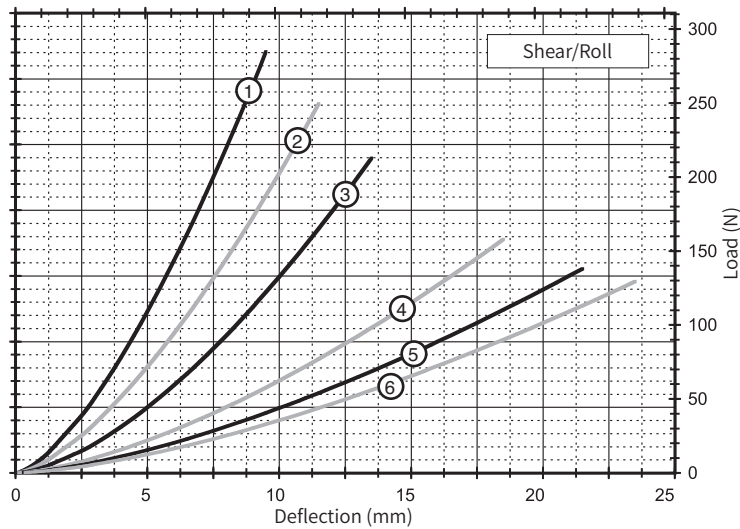

Shear/Roll

Curve	Model	Max. Static Load N	Max. Deflection mm	Kv (Vibration) kN/m	Ks (Shock) kN/m
1	WR3-100-10	44	9.7	24	24
2	WR3-200-10	40	11.7	18	18
3	WR3-400-10	31	13.7	12	12
4	WR3-600-10	27	18.8	7.0	7.0
5	WR3-700-10	22	21.8	5.3	5.3
6	WR3-800-10	18	23.9	4.4	4.4

Note: Performance provided for full loop models with standard (302/304) stainless steel cable. Please consult EKD company for other options. Do not extrapolate curves.

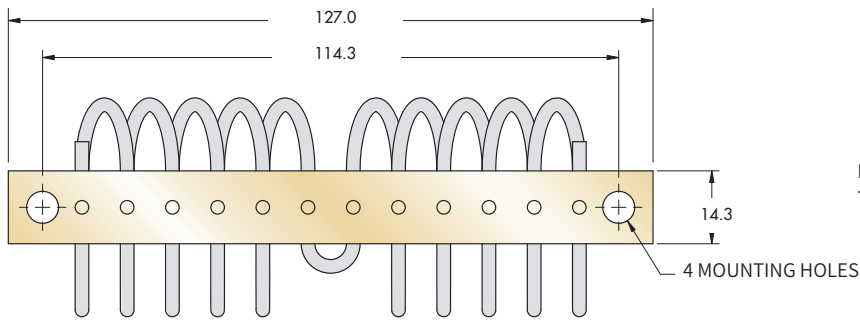

Note: Dimensions are in mm /
Tolerances are $\pm 0.25\text{mm}$

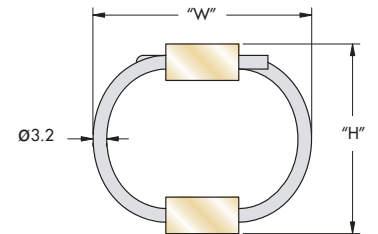
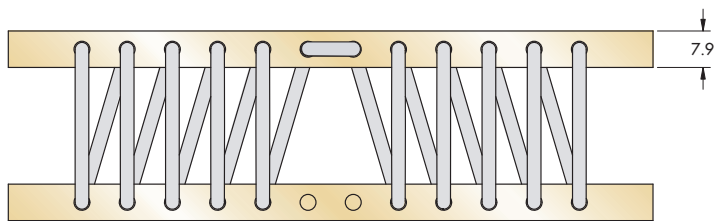

WR

Model	Height ("H") mm	Width (Ref) mm	Unit Weight Kg	Mounting Options	Thru mm	Thread mm	C'Sink Metric
WR4-100	28	36	0.12	B, D, E	$\varnothing 6.9 \pm 0.13$	M6 X 1.0	90°
WR4-200	30	38	0.12				
WR4-400	33	41	0.13				
WR4-500	36	43	0.13	A, B, C, D, E, S			
WR4-600	38	46	0.13				
WR4-700	41	48	0.14				
WR4-800	43	51	0.14				

Ordering Example

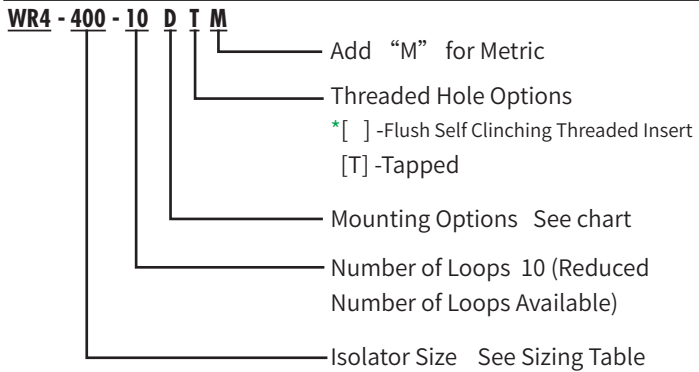

Mounting Options

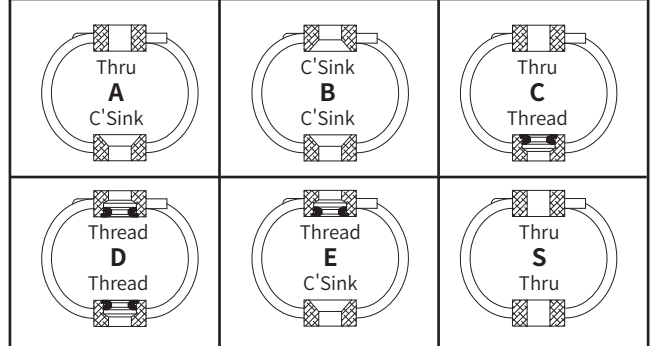

*Standard characteristics. Delivery time may be postponed for non-standard products.

- Maximum recommended torque for standard threaded insert is 3.7 Nm.
- Operating Temperature Range: -100°C~260°C

Static Load vs Deflection

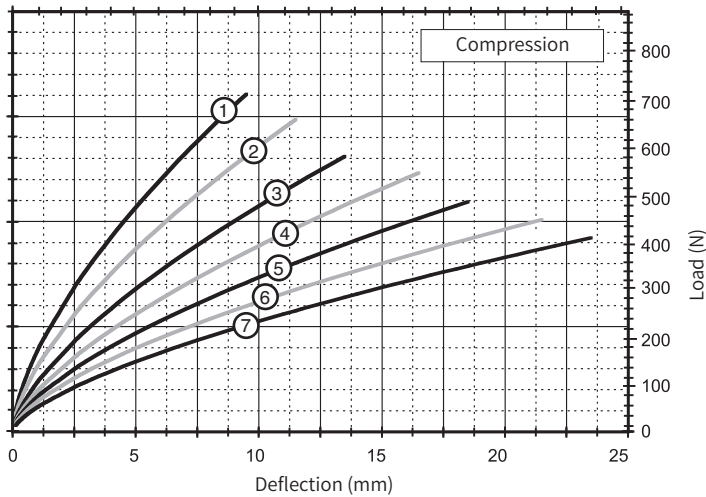

Compression

Curve	Model	Max. Static Load N	Max. Deflection mm	Kv (Vibration) kN/m	Ks (Shock) kN/m
1	WR4-100-10	213	9.7	154	91
2	WR4-200-10	194	11.7	124	68
3	WR4-400-10	166	13.7	95	51
4	WR4-500-10	156	16.8	78	39
5	WR4-600-10	142	18.8	67	32
6	WR4-700-10	133	21.8	57	25
7	WR4-800-10	117	23.9	46	21

WR

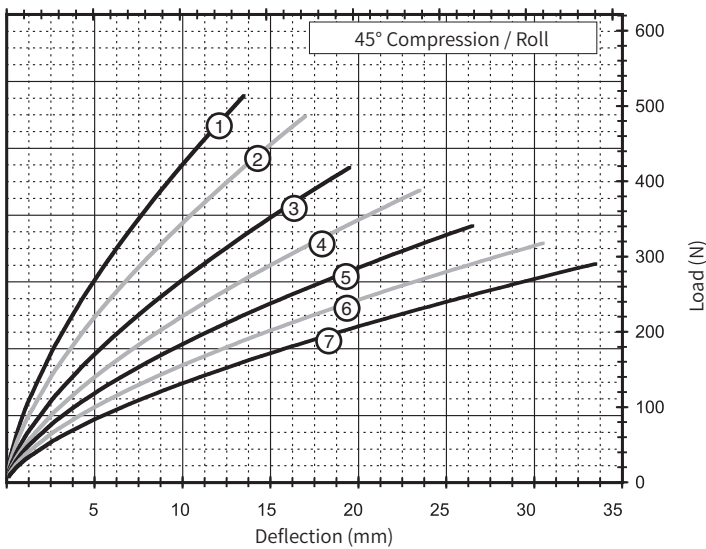

45° Compression / Roll

Curve	Model	Max. Static Load N	Max. Deflection mm	Kv (Vibration) kN/m	Ks (Shock) kN/m
1	WR4-100-10	149	13.7	86	46
2	WR4-200-10	138	17.3	70	35
3	WR4-400-10	118	19.8	53	25
4	WR4-500-10	111	23.9	44	20
5	WR4-600-10	102	26.9	39	16
6	WR4-700-10	94	31.0	32	12
7	WR4-800-10	84	34.0	26	11

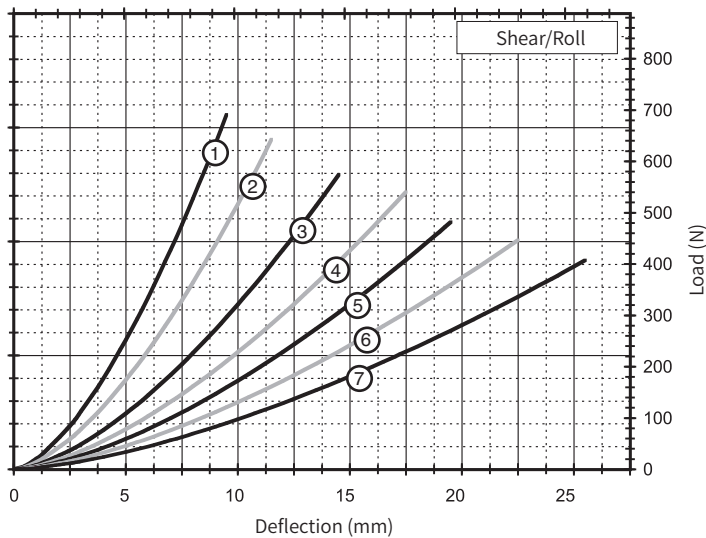

Shear/Roll

Curve	Model	Max. Static Load N	Max. Deflection mm	Kv (Vibration) kN/m	Ks (Shock) kN/m
1	WR4-100-10	111	9.7	56	56
2	WR4-200-10	98	11.7	43	43
3	WR4-400-10	93	14.7	31	31
4	WR4-500-10	85	17.8	25	25
5	WR4-600-10	80	19.8	19	19
6	WR4-700-10	71	22.9	16	16
7	WR4-800-10	62	25.9	12	12

Note: Performance provided for full loop models with standard (302/304) stainless steel cable. Please consult EKD company for other options. Do not extrapolate curves.

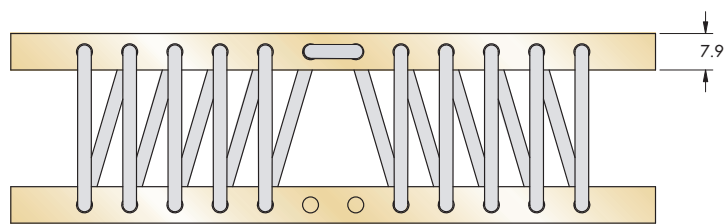
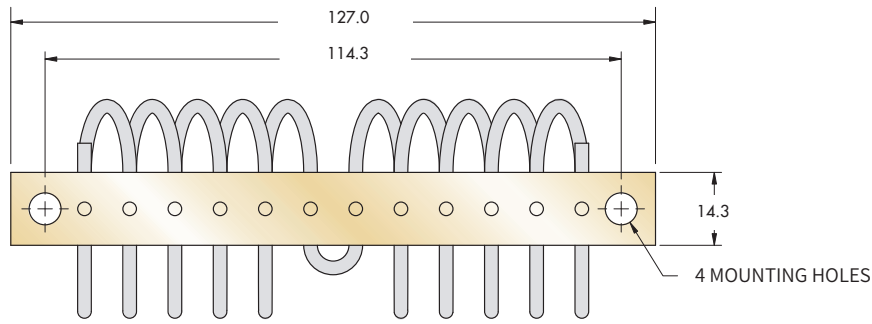

Note: Dimensions are in mm /
Tolerances are $\pm 0.25\text{mm}$

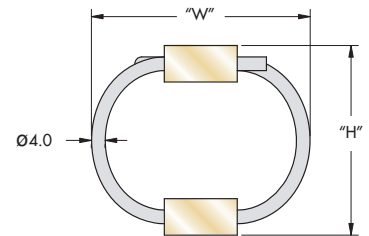

WR

Model	Height ("H") mm	Width (Ref) mm	Unit Weight Kg	Mounting Options	Thru mm	Thread mm	C'Sink Metric
WR5-200	30	41	0.15	B, D, E	$\varnothing 6.9 \pm 0.13$	M6 X 1.0	90°
WR5-400	33						
WR5-600	38						
WR5-800	46	53	0.17	A, B, C, D, E, S			
WR5-900	53						

Ordering Example

WR5 - 400 - 10 D T M

- Add "M" for Metric
- Threaded Hole Options
 - *[] -Flush Self Clinching Threaded Insert
 - [T] -Tapped
- Mounting Options See chart
- Number of Loops 10 (Reduced Number of Loops Available)
- Isolator Size See Sizing Table

Mounting Options

*Standard characteristics. Delivery time may be postponed for non-standard products.

- Maximum recommended torque for standard threaded insert is 4.3 Nm.
- Operating Temperature Range: $-100^{\circ}\text{C} \sim 260^{\circ}\text{C}$

Static Load vs Deflection

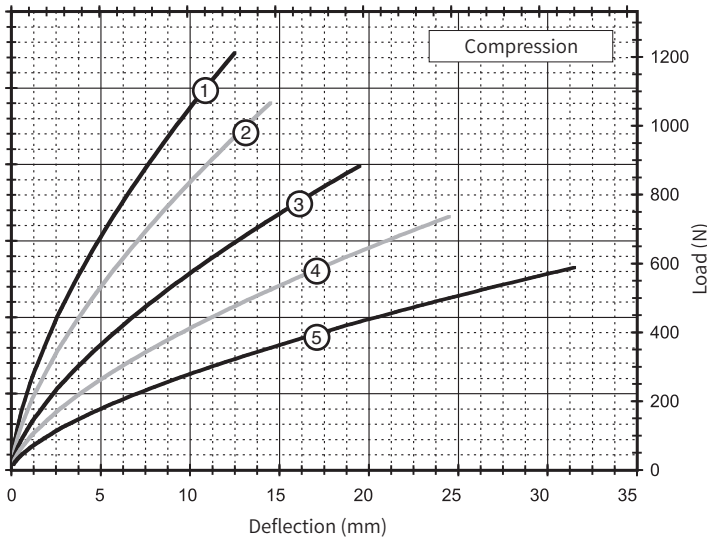

Compression

Curve	Model	Max. Static Load N	Max. Deflection mm	Kv (Vibration) kN/m	Ks (Shock) kN/m
1	WR5-200-10	364	12.7	222	117
2	WR5-400-10	309	14.7	170	88
3	WR5-600-10	257	19.8	116	54
4	WR5-800-10	216	24.9	84	37
5	WR5-900-10	172	32.0	58	23

WR

45° Compression / Roll

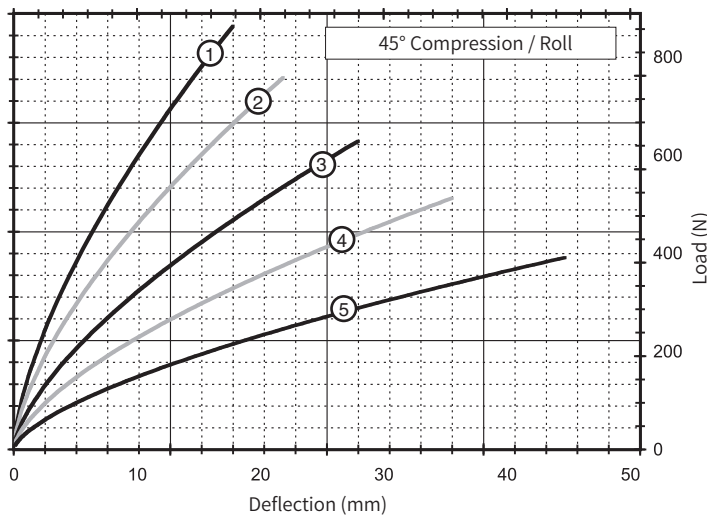

Curve	Model	Max. Static Load N	Max. Deflection mm	Kv (Vibration) kN/m	Ks (Shock) kN/m
1	WR5-200-10	254	17.8	123	60
2	WR5-400-10	218	21.8	96	42
3	WR5-600-10	182	27.9	66	28
4	WR5-800-10	151	35.6	48	18
5	WR5-900-10	115	44.7	31	11

Shear/Roll

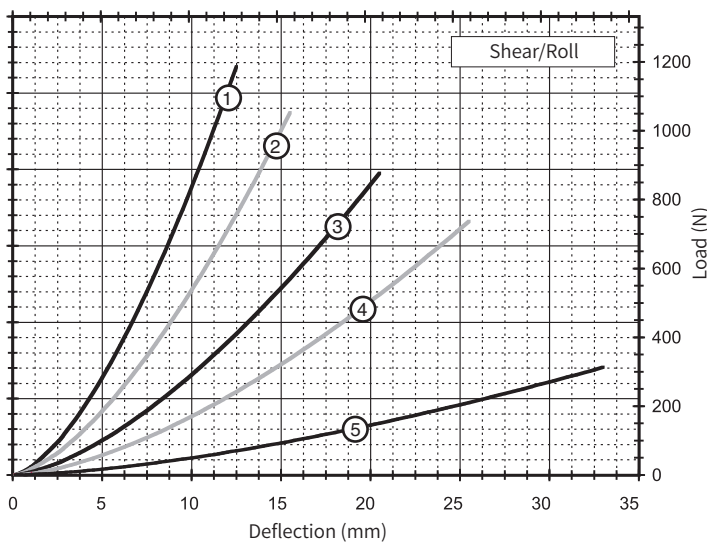

Curve	Model	Max. Static Load N	Max. Deflection mm	Kv (Vibration) kN/m	Ks (Shock) kN/m
1	WR5-200-10	178	12.7	73	73
2	WR5-400-10	156	15.7	53	53
3	WR5-600-10	133	20.8	33	33
4	WR5-800-10	111	25.9	23	23
5	WR5-900-10	40	33.5	7.9	7.9

Note: Performance provided for full loop models with standard (302/304) stainless steel cable. Please consult EKD company for other options. Do not extrapolate curves.

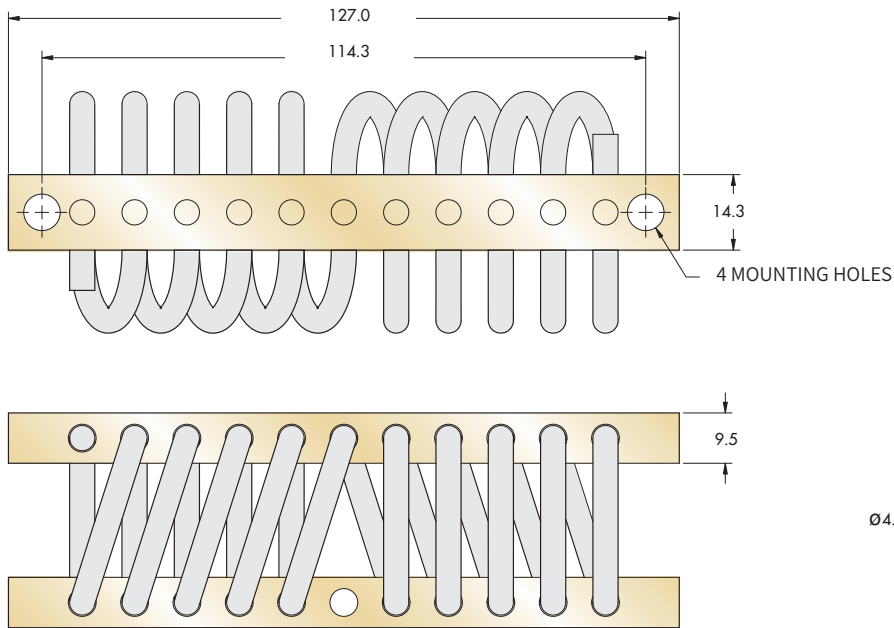

Note: Dimensions are in mm /
Tolerances are $\pm 0.25\text{mm}$

WR

Model	Height ("H") mm	Width (Ref) mm	Unit Weight Kg	Mounting Options	Thru mm	Thread mm	C'Sink Metric
WR6-200	30	36	0.19	D	$\varnothing 6.9 \pm 0.13$	M6 X 1.0	90°
WR6-300	33		0.20				
WR6-400	36		0.21	B, D, E			
WR6-500	38		0.21				
WR6-600	41		0.22				
WR6-700	43		46	0.25			
WR6-800	51	58	0.26				
WR6-850	54	75	0.27				
WR6-900	62	88	0.28				
WR6-950	81	107	0.29				

Ordering Example

WR6 - 400 - 10 D T M

- WR6 - Isolator Size See Sizing Table
- 400 - Number of Loops 10 (Reduced Number of Loops Available)
- 10 - Mounting Options See chart
- D - Threaded Hole Options
 - *[] - Flush Self Clinching Threaded Insert
 - [T] - Tapped
- T - Add "M" for Metric

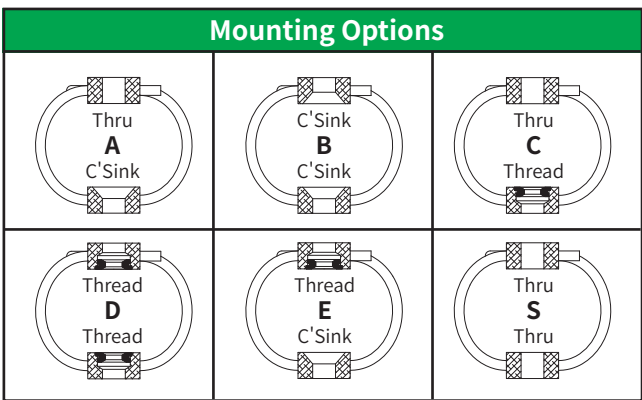

*Standard characteristics. Delivery time may be postponed for non-standard products.

- Maximum recommended torque for standard threaded insert is 4.3 Nm.
- Operating Temperature Range: -100°C~260°C

Static Load vs Deflection

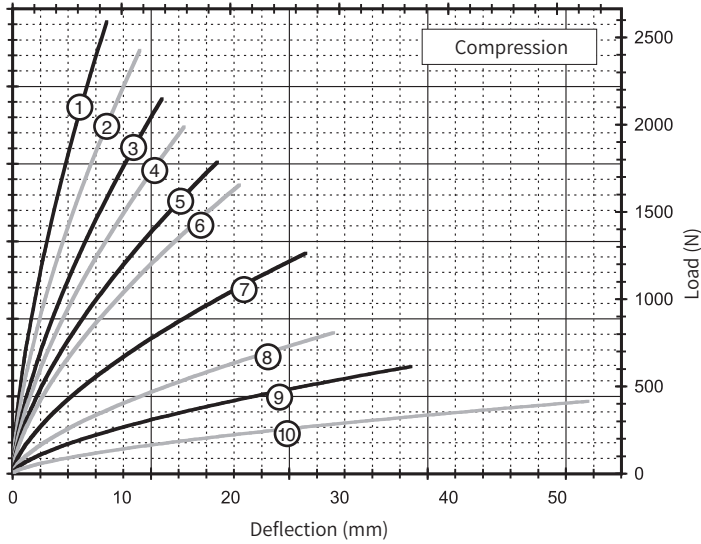

Compression

Curve	Model	Max. Static Load N	Max. Deflection mm	Kv (Vibration) kN/m	Ks (Shock) kN/m
1	WR6-200-10	734	8.6	578	363
2	WR6-300-10	712	11.7	455	252
3	WR6-400-10	601	13.7	347	189
4	WR6-500-10	578	15.7	301	152
5	WR6-600-10	512	18.8	244	117
6	WR6-700-10	489	20.8	212	96
7	WR6-800-10	365	26.9	136	58
8	WR6-850-10	236	29.5	82	33
9	WR6-900-10	178	36.6	54	21
10	WR6-950-10	120	52.8	29	10

WR

45° Compression / Roll

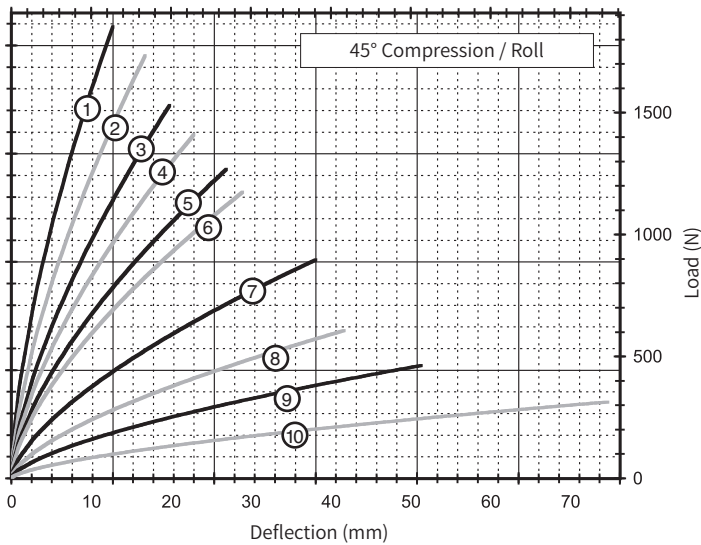

Curve	Model	Max. Static Load N	Max. Deflection mm	Kv (Vibration) kN/m	Ks (Shock) kN/m
1	WR6-200-10	534	12.7	341	179
2	WR6-300-10	512	16.8	258	126
3	WR6-400-10	432	19.8	197	93
4	WR6-500-10	409	22.9	172	75
5	WR6-600-10	373	26.9	141	58
6	WR6-700-10	350	29.0	123	49
7	WR6-800-10	260	38.1	77	28
8	WR6-850-10	177	41.7	49	18
9	WR6-900-10	136	51.3	33	11
10	WR6-950-10	91	74.7	18	5.3

Shear/Roll

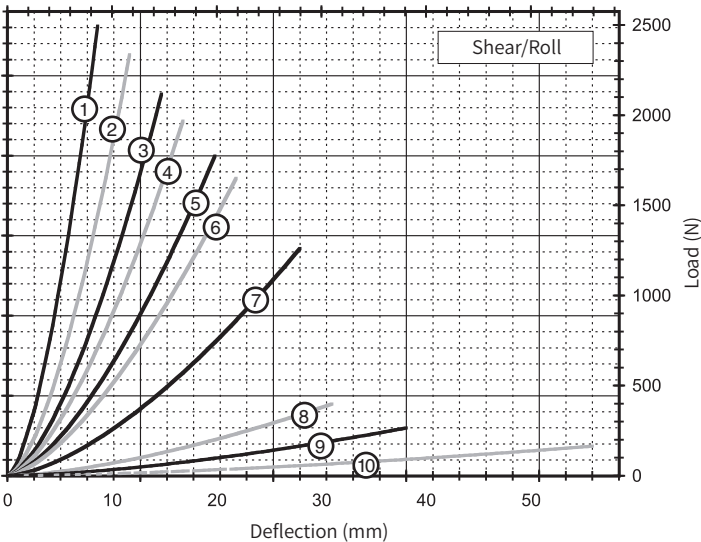

Curve	Model	Max. Static Load N	Max. Deflection mm	Kv (Vibration) kN/m	Ks (Shock) kN/m
1	WR6-200-10	356	8.6	224	224
2	WR6-300-10	356	11.7	156	156
3	WR6-400-10	334	14.7	112	112
4	WR6-500-10	311	16.8	93	93
5	WR6-600-10	289	19.8	70	70
6	WR6-700-10	267	21.8	60	60
7	WR6-800-10	200	27.9	35	35
8	WR6-850-10	58	31.0	11	11
9	WR6-900-10	40	38.1	5.3	5.3
10	WR6-950-10	22	55.9	2.3	2.3

Note: Performance provided for full loop models with standard (302/304) stainless steel cable. Please consult EKD company for other options. Do not extrapolate curves.

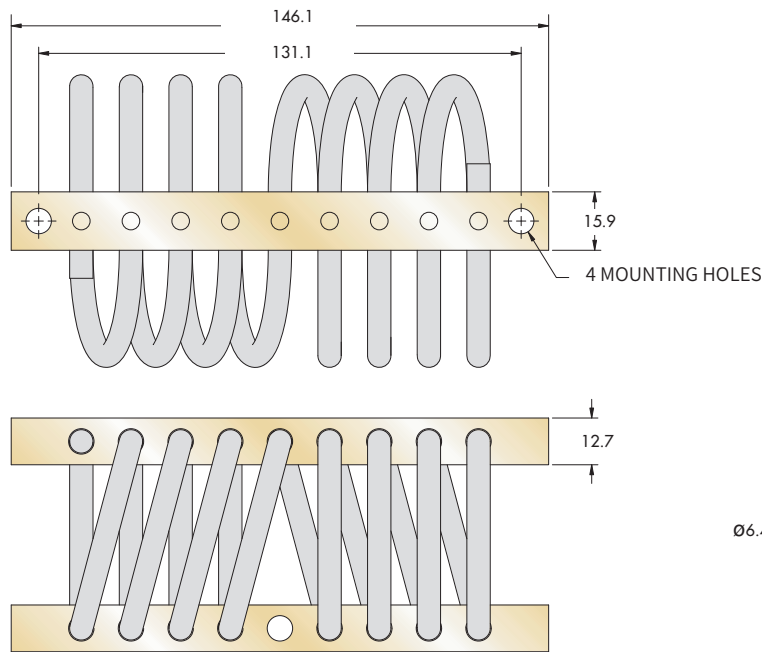

Note: Dimensions are in mm /
Tolerances are $\pm 0.25\text{mm}$

WR

Model	Height ("H") mm	Width (Ref) mm	Unit Weight Kg	Mounting Options	Thru mm	Thread mm	C'Sink Metric
WR8-200	48	± 2.54	56	A, B, C, D, E, S	$\text{Ø}6.9 \pm 0.13$	M6 X 1.0	90°
WR8-400	54		64				
WR8-500	59		71				
WR8-600	64		80				
WR8-700	64		89				
WR8-800	67	± 3.81	95				
WR8-850	67		100				
WR8-900	83		108				

Ordering Example

WR8 - 400 - 8 D T M

- WR8 - Isolator Size See Sizing Table
- 400 - Number of Loops 8 (Reduced Number of Loops Available)
- 8 - Mounting Options See chart
- D - Add "M" for Metric
- T - Threaded Hole Options
- M - * [] - Flush Self Clinching Threaded Insert
[T] - Tapped

Mounting Options

*Standard characteristics. Delivery time may be postponed for non-standard products.

- Maximum recommended torque for standard threaded insert is 4.3 Nm.
- Operating Temperature Range: -100°C~260°C

Static Load vs Deflection

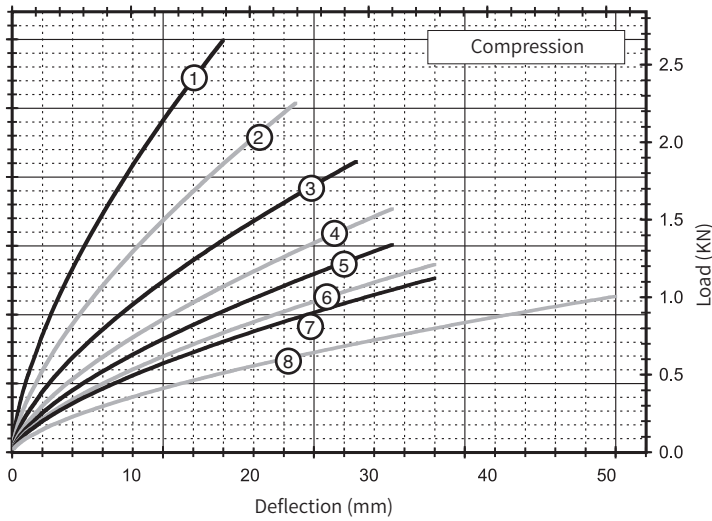

Compression

Curve	Model	Max. Static Load N	Max. Deflection mm	Kv (Vibration) kN/m	Ks (Shock) kN/m
1	WR8-200-08	778	17.8	382	182
2	WR8-400-08	667	23.9	266	116
3	WR8-500-08	556	29.0	196	79
4	WR8-600-08	445	32.0	151	60
5	WR8-700-08	386	32.0	127	51
6	WR8-800-08	351	35.6	109	42
7	WR8-850-08	325	35.6	100	39
8	WR8-900-08	297	50.8	74	25

WR

45° Compression / Roll

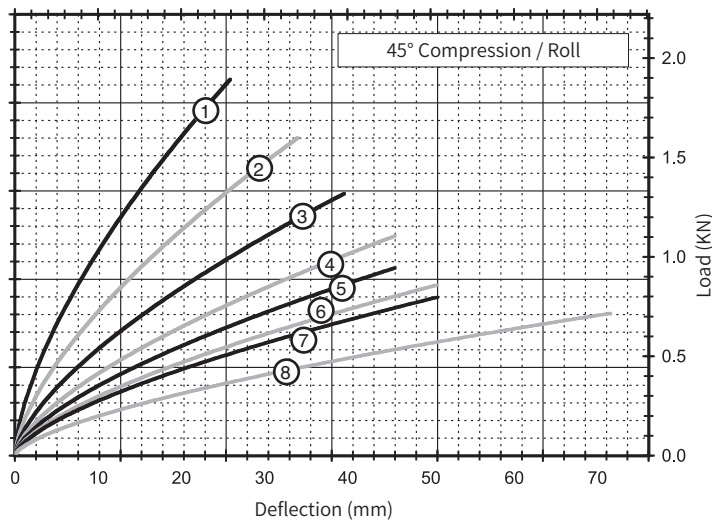

Curve	Model	Max. Static Load N	Max. Deflection mm	Kv (Vibration) kN/m	Ks (Shock) kN/m
1	WR8-200-08	556	25.9	215	89
2	WR8-400-08	467	34.0	151	58
3	WR8-500-08	390	39.6	109	40
4	WR8-600-08	321	45.7	86	30
5	WR8-700-08	273	45.7	72	25
6	WR8-800-08	248	50.8	61	21
7	WR8-850-08	229	50.8	56	19
8	WR8-900-08	209	71.6	41	12

Shear/Roll

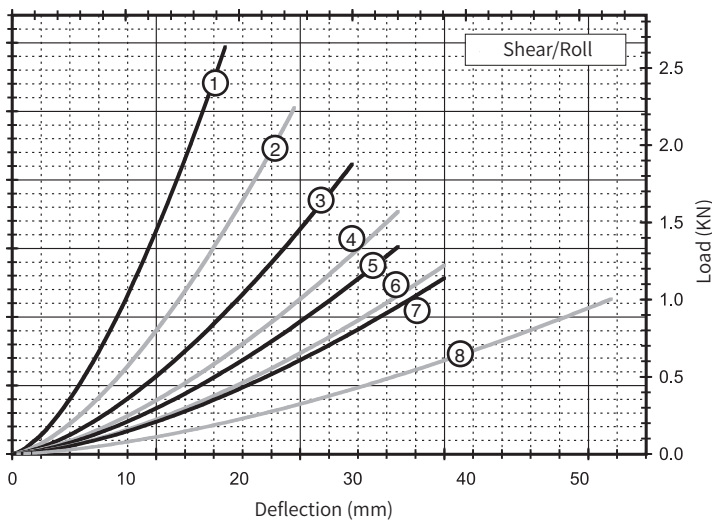

Curve	Model	Max. Static Load N	Max. Deflection mm	Kv (Vibration) kN/m	Ks (Shock) kN/m
1	WR8-200-08	423	18.8	110	110
2	WR8-400-08	356	24.9	72	72
3	WR8-500-08	311	30.0	49	49
4	WR8-600-08	245	34.0	37	37
5	WR8-700-08	222	34.0	32	32
6	WR8-800-08	200	38.1	25	25
7	WR8-850-08	178	38.1	23	23
8	WR8-900-08	156	52.8	16	16

Note: Performance provided for full loop models with standard (302/304) stainless steel cable. Please consult EKD company for other options. Do not extrapolate curves.

6-Loop

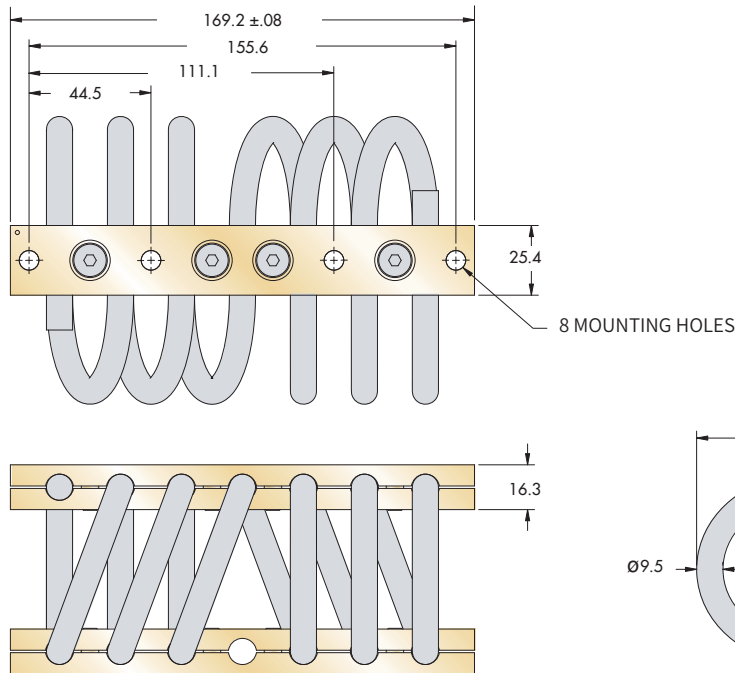

Note: Dimensions are in mm /
Tolerances are ±0.25mm

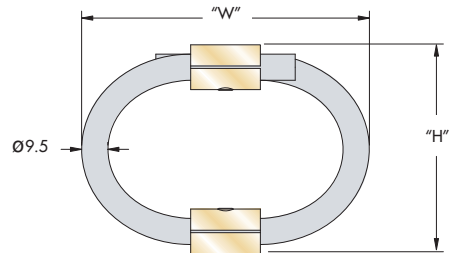

Model	Height ("H") mm	Width (Ref) mm	Unit Weight Kg	Mounting Options	Thru mm	Thread mm	C'Sink Metric
WR12-206	71	84	0.83	A, B, C, D, E, S	Ø9.0 +0.13 -0.38	M6 X 1.0	90°
WR12-306	74	89	0.85				
WR12-406	76	105	0.90				
WR12-506	83	108	0.95				
WR12-606	89	108	0.98				
WR12-706	105	121	1.07				
WR12-806	108	140	1.12				

Ordering Example

WR12-406-6 D H M

- WR12 - Isolator Size See Sizing Table
- 406 - Number of Loops 6 (Reduced Number of Loops Available)
- 6 - Mounting Options See chart
- D - Helical Insert, Free Running
- H - Helical Insert, Self Locking
- M - Add "M" for Metric

Threaded Hole Options
* [] - Tapped

Mounting Options

*Standard characteristics. Delivery time may be postponed for non-standard products.

- Maximum recommended torque for standard threaded insert is 10 Nm.
- Operating Temperature Range: -100°C~260°C

6-Loop

Static Load vs Deflection

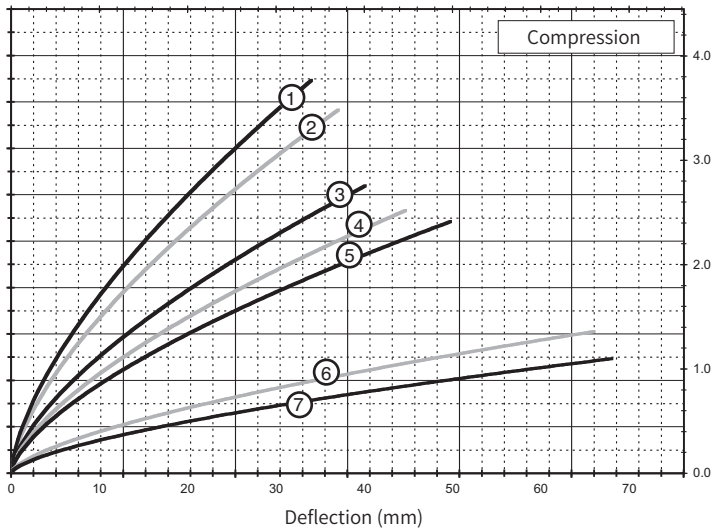

Compression

Curve	Model	Max. Static Load N	Max. Deflection mm	Kv (Vibration) kN/m	Ks (Shock) kN/m
1	WR12-206-06	1 090	34.0	275	135
2	WR12-306-06	1 023	37.1	240	114
3	WR12-406-06	801	40.1	180	84
4	WR12-506-06	734	44.7	154	68
5	WR12-606-06	712	49.8	137	60
6	WR12-706-06	396	66.0	65	25
7	WR12-806-06	320	68.1	51	19

45° Compression / Roll

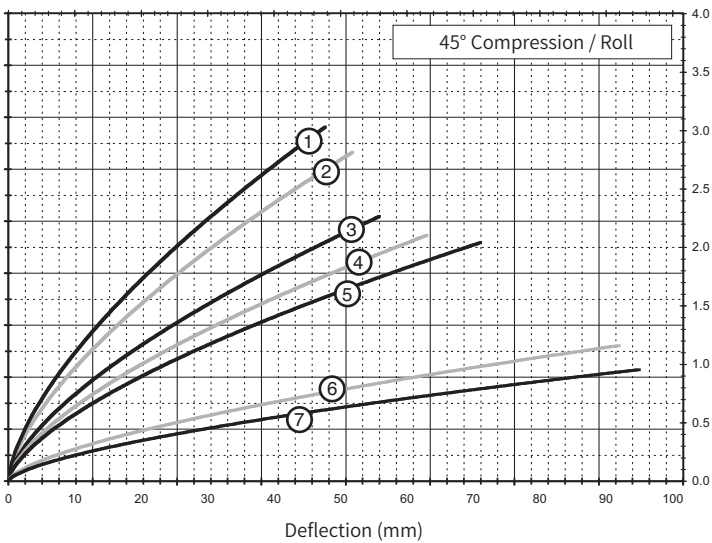

Curve	Model	Max. Static Load N	Max. Deflection mm	Kv (Vibration) kN/m	Ks (Shock) kN/m
1	WR12-206-06	890	47.8	177	77
2	WR12-306-06	823	51.8	156	67
3	WR12-406-06	667	55.9	120	49
4	WR12-506-06	623	63.0	103	40
5	WR12-606-06	601	71.1	92	35
6	WR12-706-06	341	91.9	44	16
7	WR12-806-06	280	95.0	36	12

Shear/Roll

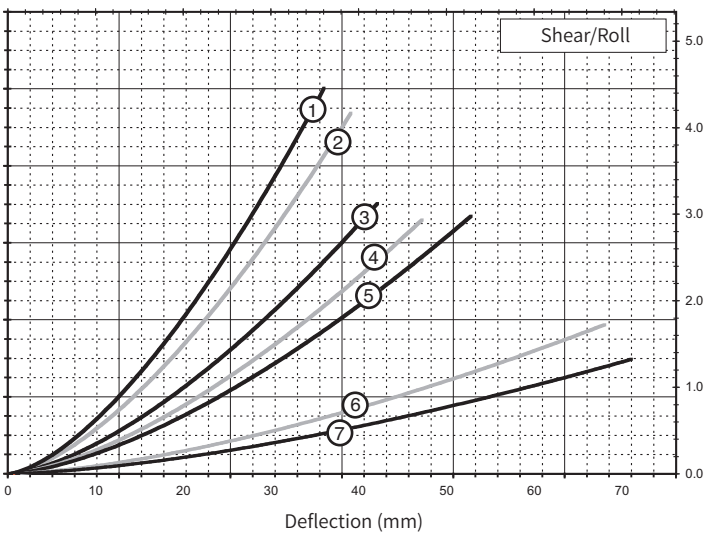

Curve	Model	Max. Static Load N	Max. Deflection mm	Kv (Vibration) kN/m	Ks (Shock) kN/m
1	WR12-206-06	689	36.1	98	98
2	WR12-306-06	645	39.1	84	84
3	WR12-406-06	489	42.2	58	58
4	WR12-506-06	467	47.2	49	49
5	WR12-606-06	445	52.8	44	44
6	WR12-706-06	200	68.1	20	20
7	WR12-806-06	156	71.1	15	15

Note: Performance provided for full loop models with standard (302/304) stainless steel cable. Please consult EKD company for other options. Do not extrapolate curves.

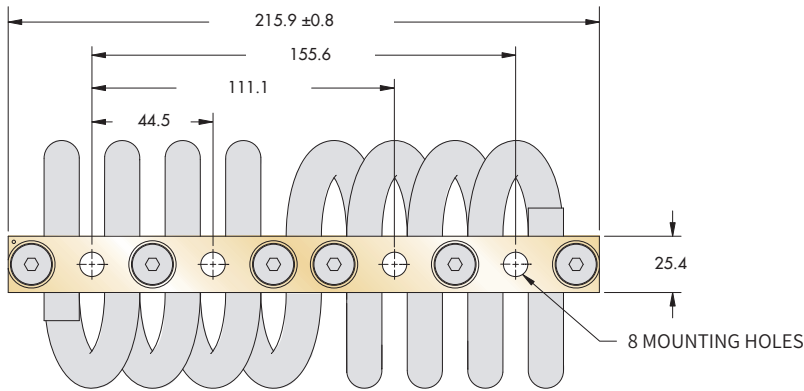

Note: Dimensions are in mm / Tolerances are ±0.25mm

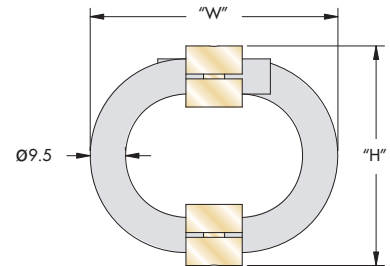
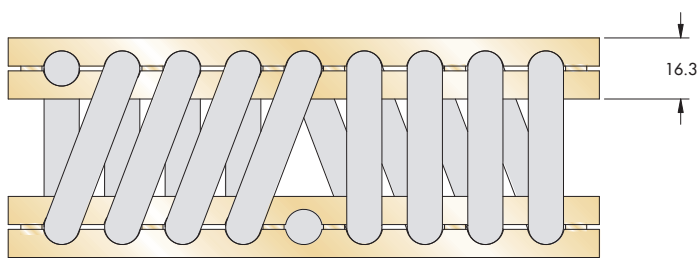

Model	Height ("H") mm	Width (Ref) mm	Unit Weight Kg	Mounting Options	Thru mm	Thread mm	C'Sink Metric
WR12-200	71	84	1.10	A, B, C, D, E, S	Ø9.0 ^{+0.13} _{-0.38}	*M8 X 1.25	90°
WR12-300	74	89	1.13				
WR12-400	76	105	1.20				
WR12-500	83	108	1.26				
WR12-600	89	108	1.30				
WR12-700	105	121	1.43				
WR12-800	108	140	1.50				

* Tapped M8 x 1.25, Inserts M6 x 1.0

Ordering Example

WR12-400-8 D H M

- WR12 - Isolator Size See Sizing Table
- 400 - Number of Loops 8 (Reduced Number of Loops Available)
- 8 - Mounting Options See chart
- D - Threaded Hole Options
 - * [] - Tapped
 - [H] - Helical Insert, Free Running
 - [L] - Helical Insert, Self Locking
- H - Add "M" for Metric

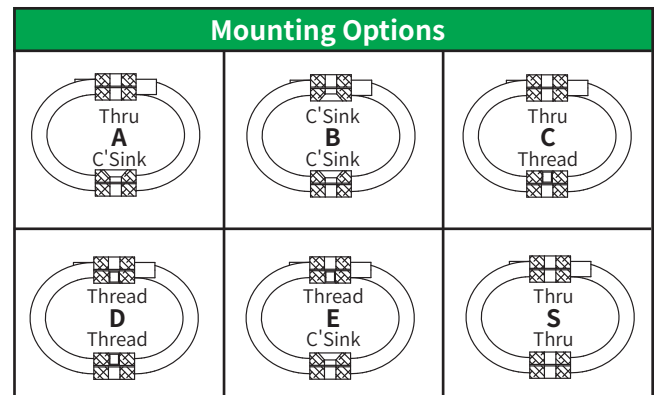

*Standard characteristics. Delivery time may be postponed for non-standard products.

- Maximum recommended torque for standard threaded insert is 20 Nm.
- Operating Temperature Range: -100°C~260°C

Static Load vs Deflection

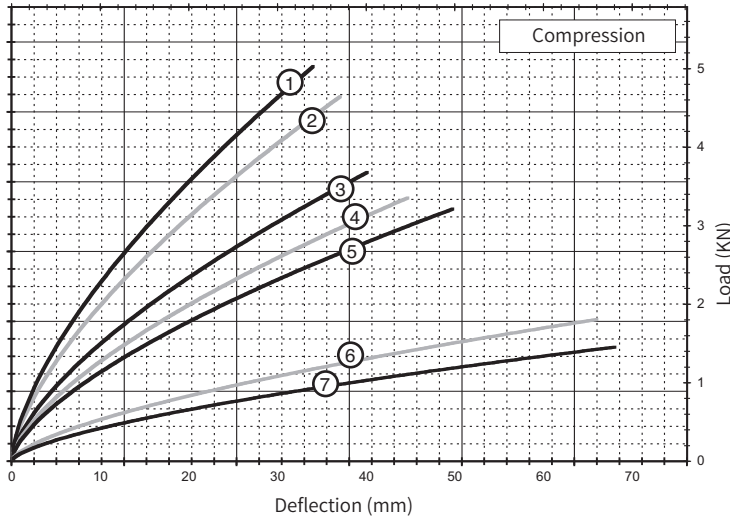

Compression

Curve	Model	Max. Static Load N	Max. Deflection mm	Kv (Vibration) kN/m	Ks (Shock) kN/m
1	WR12-200-08	1 468	34.0	366	179
2	WR12-300-08	1 357	37.1	320	152
3	WR12-400-08	1 068	40.1	242	110
4	WR12-500-08	979	44.7	205	91
5	WR12-600-08	934	49.8	182	79
6	WR12-700-08	534	66.0	86	33
7	WR12-800-08	423	68.1	67	26

WR

45° Compression / Roll

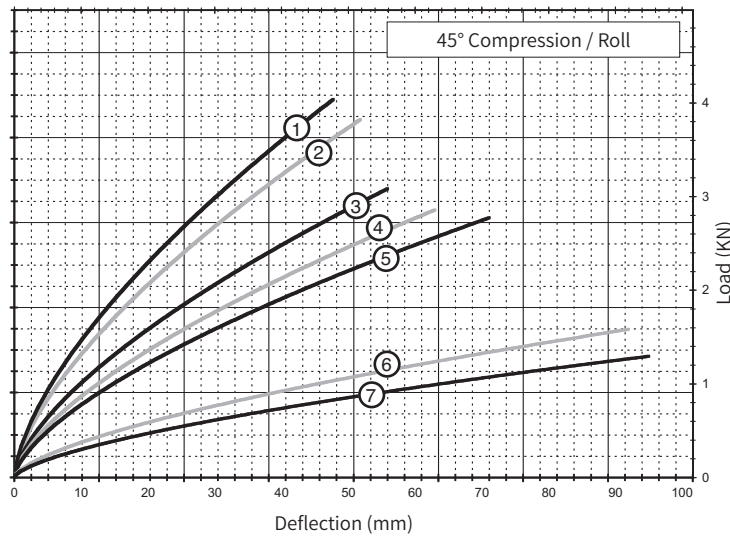

Curve	Model	Max. Static Load N	Max. Deflection mm	Kv (Vibration) kN/m	Ks (Shock) kN/m
1	WR12-200-08	1 179	47.8	236	103
2	WR12-300-08	1 090	51.8	208	88
3	WR12-400-08	890	55.9	159	65
4	WR12-500-08	823	63.0	137	54
5	WR12-600-08	778	71.1	123	47
6	WR12-700-08	467	91.9	60	21
7	WR12-800-08	373	95.0	47	16

Shear/Roll

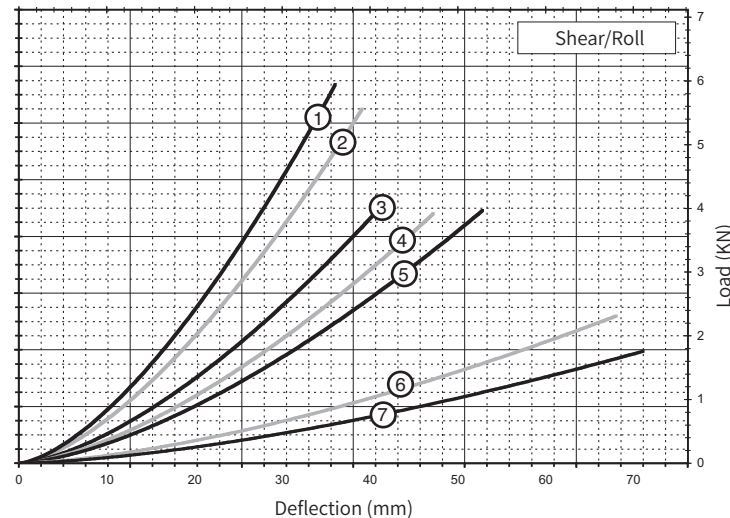

Curve	Model	Max. Static Load N	Max. Deflection mm	Kv (Vibration) kN/m	Ks (Shock) kN/m
1	WR12-200-08	912	36.1	130	130
2	WR12-300-08	867	39.1	112	112
3	WR12-400-08	667	42.2	77	77
4	WR12-500-08	623	47.2	65	65
5	WR12-600-08	601	52.8	60	60
6	WR12-700-08	267	68.1	27	27
7	WR12-800-08	200	71.1	19	19

Note: Performance provided for full loop models with standard (302/304) stainless steel cable. Please consult EKD company for other options. Do not extrapolate curves.

6-Loop

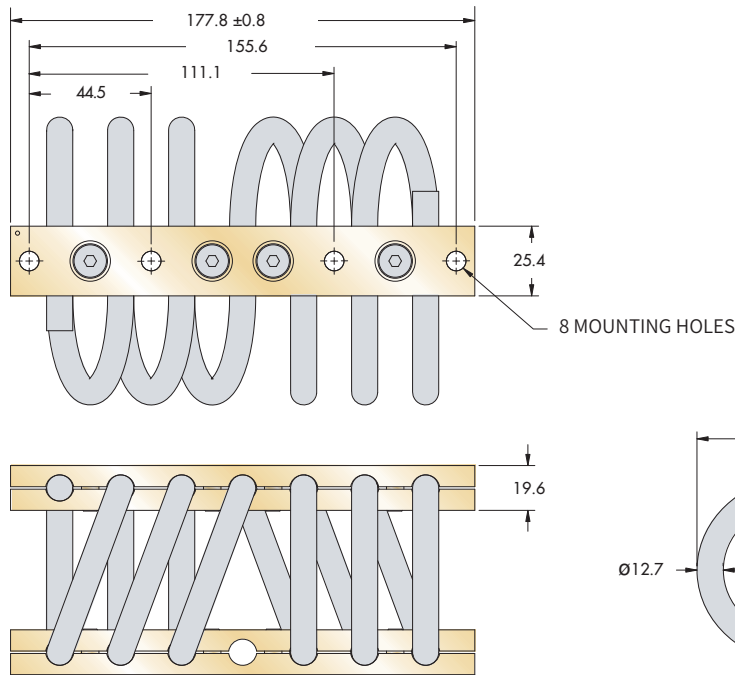

Note: Dimensions are in mm /
Tolerances are ±0.25mm



Model	Height ("H") mm	Width (Ref) mm	Unit Weight Kg	Mounting Options	Thru mm	Thread mm	C'Sink Metric
WR16-206	76	92	1.36	A, B, C, D, E, S	Ø9.0 ^{+0.13} -0.38	*M8 X 1.25	90°
WR16-306	83	102	1.43				
WR16-406	89	105	1.50				
WR16-606	95	121	1.67				
WR16-706	108	133	1.81				
WR16-806	124	144	2.02				
WR16-856	137	156	2.18				
WR16-906	155	180	2.31				

* Tapped M8 x 1.25, Inserts M7 x 1.0

Ordering Example

WR16-406-6 D H M

- Add "M" for Metric
- Threaded Hole Options
* [] -Tapped
[H] -Helical Insert, Free Running
[L] -Helical Insert, Self Locking
- Mounting Options See chart
- Number of Loops 6 (Reduced Number of Loops Available)
- Isolator Size See Sizing Table

Mounting Options

*Standard characteristics. Delivery time may be postponed for non-standard products.

- Maximum recommended torque for standard threaded insert is 20 Nm.
- Operating Temperature Range: -100°C~260°C

6-Loop

Static Load vs Deflection

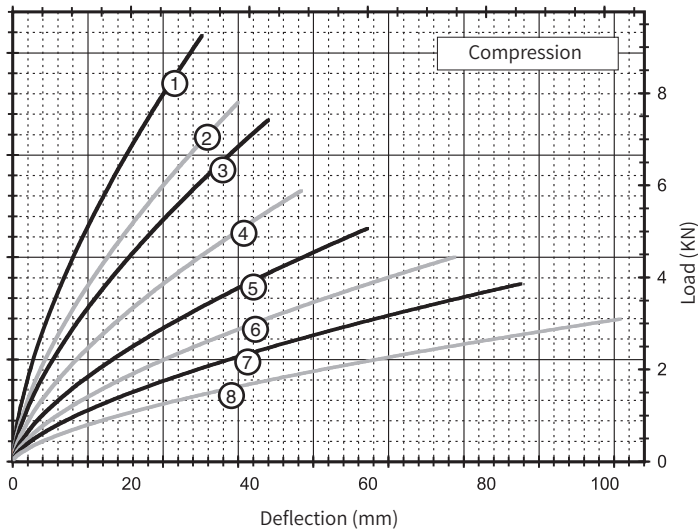

Compression

Curve	Model	Max. Static Load N	Max. Deflection mm	Kv (Vibration) kN/m	Ks (Shock) kN/m
1	WR16-206-06	2 736	32.0	716	352
2	WR16-306-06	2 291	38.1	531	249
3	WR16-406-06	2 157	43.2	461	208
4	WR16-606-06	1 735	48.8	343	147
5	WR16-706-06	1 468	59.9	256	103
6	WR16-806-06	1 290	74.7	196	72
7	WR16-856-06	1 134	85.9	154	54
8	WR16-906-06	912	102.6	111	37

WR

45° Compression / Roll

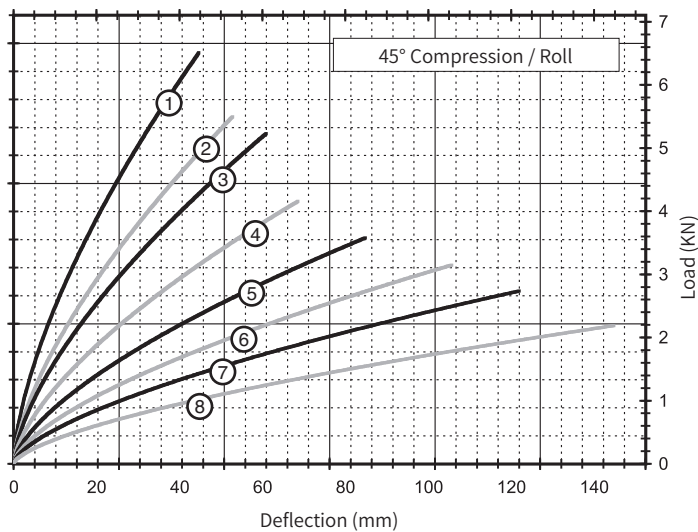

Curve	Model	Max. Static Load N	Max. Deflection mm	Kv (Vibration) kN/m	Ks (Shock) kN/m
1	WR16-206-06	1 935	44.7	405	177
2	WR16-306-06	1 624	52.8	298	126
3	WR16-406-06	1 535	61.0	263	105
4	WR16-606-06	1 223	68.6	194	74
5	WR16-706-06	1 045	84.8	144	51
6	WR16-806-06	912	105.7	110	37
7	WR16-856-06	801	121.9	88	28
8	WR16-906-06	623	144.8	62	19

Shear/Roll

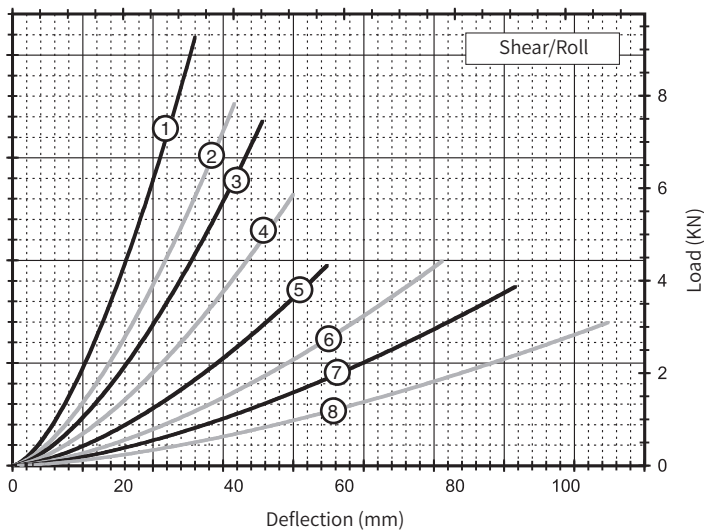

Curve	Model	Max. Static Load N	Max. Deflection mm	Kv (Vibration) kN/m	Ks (Shock) kN/m
1	WR16-206-06	1 490	33.0	221	221
2	WR16-306-06	1 223	40.1	156	156
3	WR16-406-06	1 134	45.2	130	130
4	WR16-606-06	912	50.8	91	91
5	WR16-706-06	601	56.9	60	60
6	WR16-806-06	445	77.7	46	46
7	WR16-856-06	334	90.9	33	33
8	WR16-906-06	222	107.7	23	23

Note: Performance provided for full loop models with standard (302/304) stainless steel cable. Please consult EKD company for other options. Do not extrapolate curves.

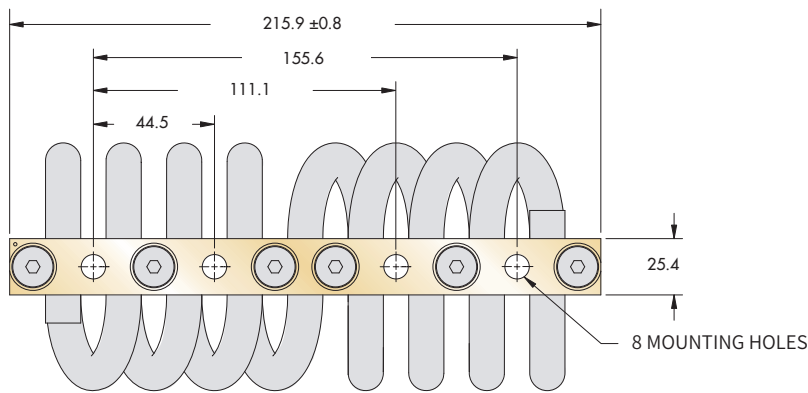

Note: Dimensions are in mm /
Tolerances are ±0.25mm

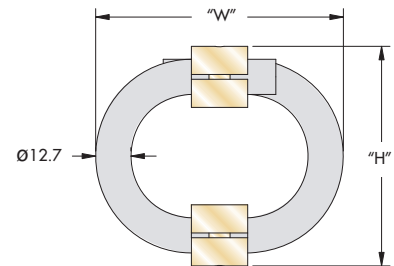
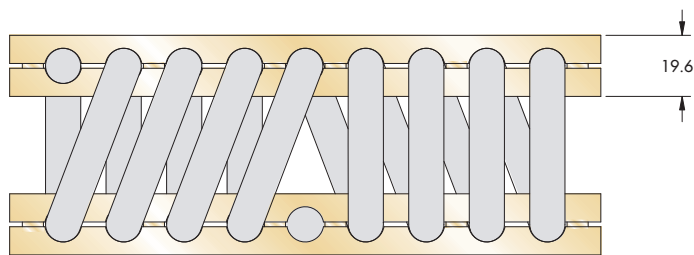

WR

Model	Height ("H") mm	Width (Ref) mm	Unit Weight Kg	Mounting Options	Thru mm	Thread mm	C'Sink Metric
WR16-200	76	92	1.81	A, B, C, D, E, S	Ø9.0 ^{+0.13} -0.38	*M8 X 1.25	90°
WR16-300	83	102	1.91				
WR16-400	89	105	2.00				
WR16-600	95	121	2.22				
WR16-700	108	133	2.40				
WR16-800	124	144	2.70				
WR16-850	137	156	2.90				
WR16-900	155	180	3.09				

* Tapped M8 x 1.25, Inserts M7 x 1.0

Ordering Example

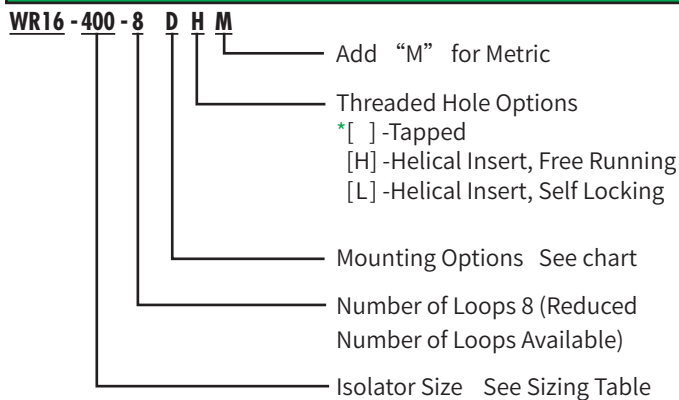

Mounting Options

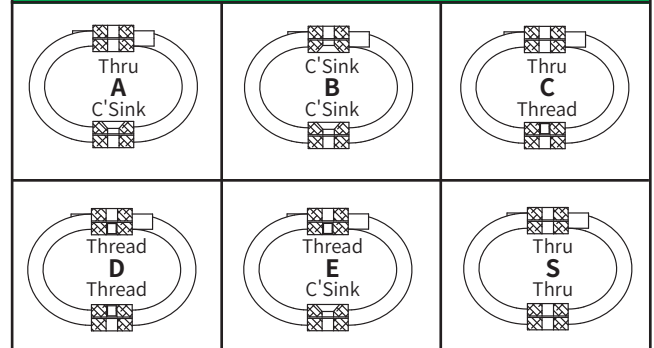

*Standard characteristics. Delivery time may be postponed for non-standard products.

- Maximum recommended torque for standard threaded insert is 20 Nm.
- Operating Temperature Range: -100°C~260°C

Static Load vs Deflection

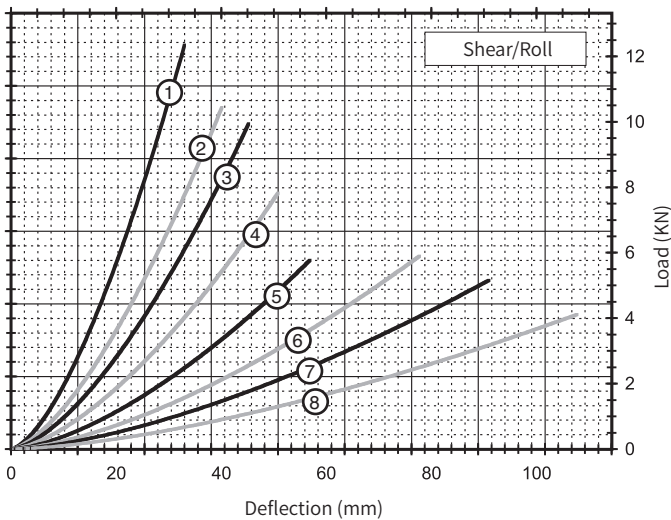
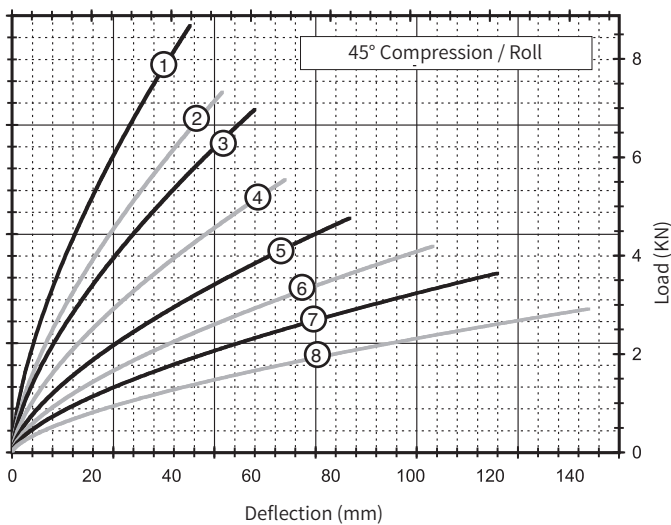
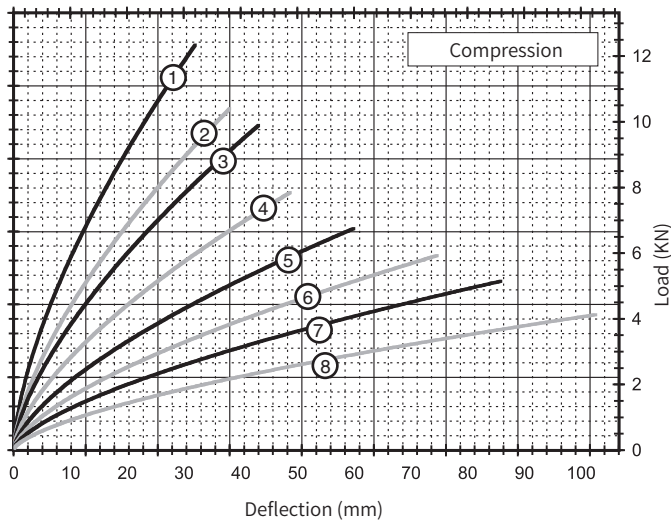

Compression

Curve	Model	Max. Static Load N	Max. Deflection mm	Kv (Vibration) kN/m	Ks (Shock) kN/m
1	WR16-200-08	3 648	32.0	954	471
2	WR16-300-08	3 047	38.1	708	333
3	WR16-400-08	2 869	43.2	613	278
4	WR16-600-08	2 313	48.8	457	196
5	WR16-700-08	1 957	59.9	340	137
6	WR16-800-08	1 735	74.7	261	96
7	WR16-850-08	1 512	85.9	207	74
8	WR16-900-08	1 201	102.6	148	49

45° Compression / Roll

Curve	Model	Max. Static Load N	Max. Deflection mm	Kv (Vibration) kN/m	Ks (Shock) kN/m
1	WR16-200-08	2 580	44.7	539	236
2	WR16-300-08	2 157	52.8	398	168
3	WR16-400-08	2 046	61.0	349	138
4	WR16-600-08	1 624	68.6	259	98
5	WR16-700-08	1 401	84.8	193	68
6	WR16-800-08	1 223	105.7	147	49
7	WR16-850-08	1 068	121.9	117	37
8	WR16-900-08	823	144.8	83	25

Shear/Roll

Curve	Model	Max. Static Load N	Max. Deflection mm	Kv (Vibration) kN/m	Ks (Shock) kN/m
1	WR16-200-08	2 936	33.0	294	294
2	WR16-300-08	1 713	40.1	207	207
3	WR16-400-08	1 557	45.2	173	173
4	WR16-600-08	1 201	50.8	121	121
5	WR16-700-08	801	56.9	81	81
6	WR16-800-08	601	77.7	60	60
7	WR16-850-08	445	90.9	46	46
8	WR16-900-08	289	107.7	30	30

Note: Performance provided for full loop models with standard (302/304) stainless steel cable. Please consult EKD company for other options. Do not extrapolate curves.

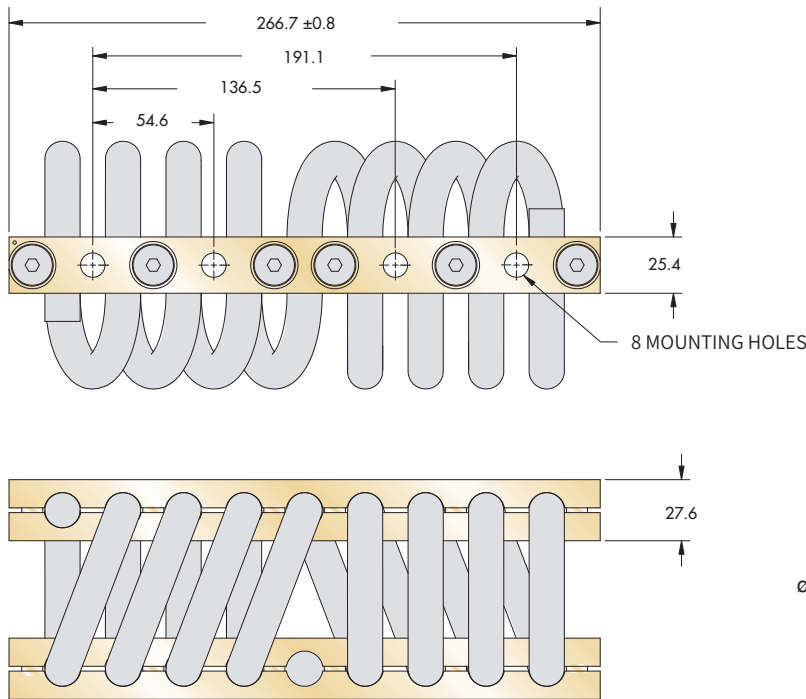

Note: Dimensions are in mm /
Tolerances are ±0.25mm

WR

Model	Height ("H") mm	Width (Ref) mm	Unit Weight Kg	Mounting Options	Thru mm	Thread mm	C'Sink Metric
WR20-200	89	102	3.00	C, D	Ø11.0 +0.13 -0.38	M10 X 1.5	90°
WR20-300	99	112	3.20	A, B, C, D, E, S			
WR20-400	102	121	3.40				
WR20-600	109	135	3.70				
WR20-700	119	152	4.00				
WR20-800	127	165	4.31				
WR20-900	135	178	4.63				

Ordering Example

WR20 - 400 - 8 D H M

- Add "M" for Metric
- Threaded Hole Options
* [] - Tapped
- [H] - Helical Insert, Free Running
- [L] - Helical Insert, Self Locking
- Mounting Options See chart
- Number of Loops 8 (Reduced
Number of Loops Available)
- Isolator Size See Sizing Table

Mounting Options

*Standard characteristics. Delivery time may be postponed for non-standard products.

- Maximum recommended torque for standard threaded insert is 50 Nm.
- Operating Temperature Range: -100°C~260°C

Static Load vs Deflection

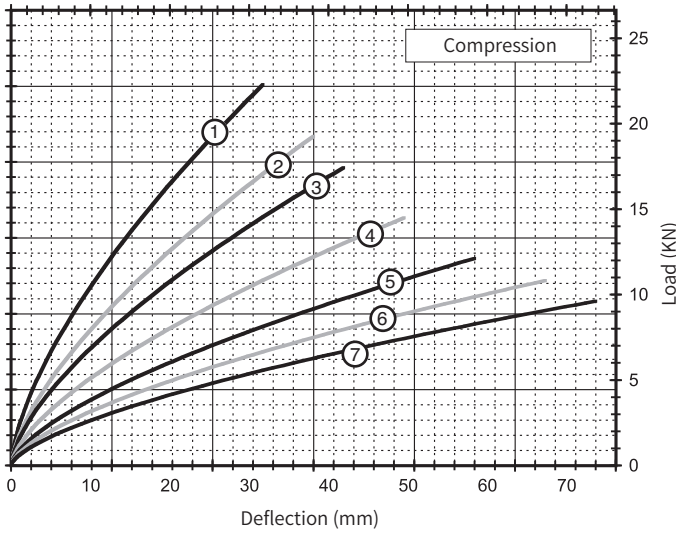

Compression

Curve	Model	Max. Static Load N	Max. Deflection mm	Kv (Vibration) kN/m	Ks (Shock) kN/m
1	WR20-200-08	6 450	31.8	1 676	849
2	WR20-300-08	5 471	38.1	1 259	609
3	WR20-400-08	5 071	41.9	1 105	504
4	WR20-600-08	4 204	49.5	821	356
5	WR20-700-08	3 514	58.4	616	252
6	WR20-800-08	3 180	67.3	511	196
7	WR20-900-08	2 802	73.7	427	159

WR

45° Compression / Roll

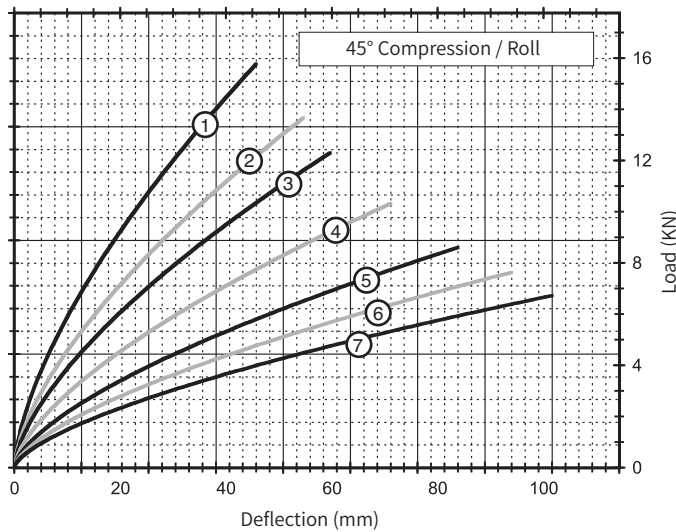

Curve	Model	Max. Static Load N	Max. Deflection mm	Kv (Vibration) kN/m	Ks (Shock) kN/m
1	WR20-200-08	4 537	45.7	951	419
2	WR20-300-08	3 981	54.6	741	305
3	WR20-400-08	3 581	59.7	627	250
4	WR20-600-08	2 980	71.1	468	177
5	WR20-700-08	2 491	83.8	350	124
6	WR20-800-08	2 246	94.0	285	98
7	WR20-900-08	1 979	101.6	238	81

Shear/Roll

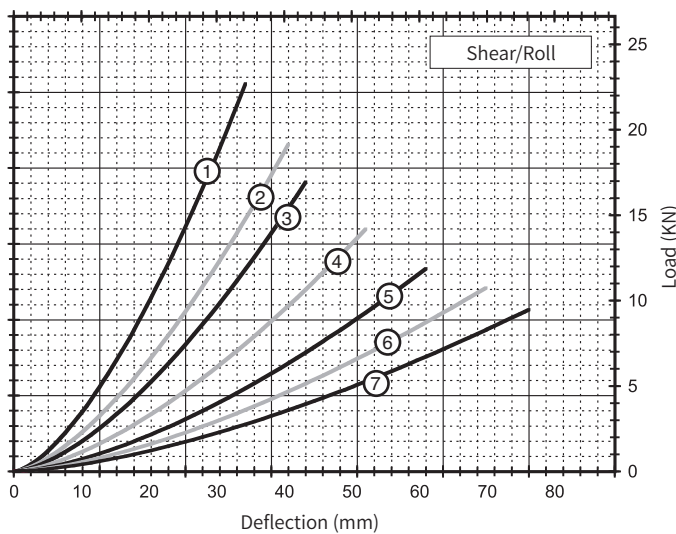

Curve	Model	Max. Static Load N	Max. Deflection mm	Kv (Vibration) kN/m	Ks (Shock) kN/m
1	WR20-200-08	3 514	34.3	524	524
2	WR20-300-08	3 025	40.6	375	375
3	WR20-400-08	2 624	43.2	308	308
4	WR20-600-08	2 135	52.1	215	215
5	WR20-700-08	1 512	61.0	152	152
6	WR20-800-08	1 223	69.9	123	123
7	WR20-900-08	979	76.2	98	98

Note: Performance provided for full loop models with standard (302/304) stainless steel cable. Please consult EKD company for other options. Do not extrapolate curves.

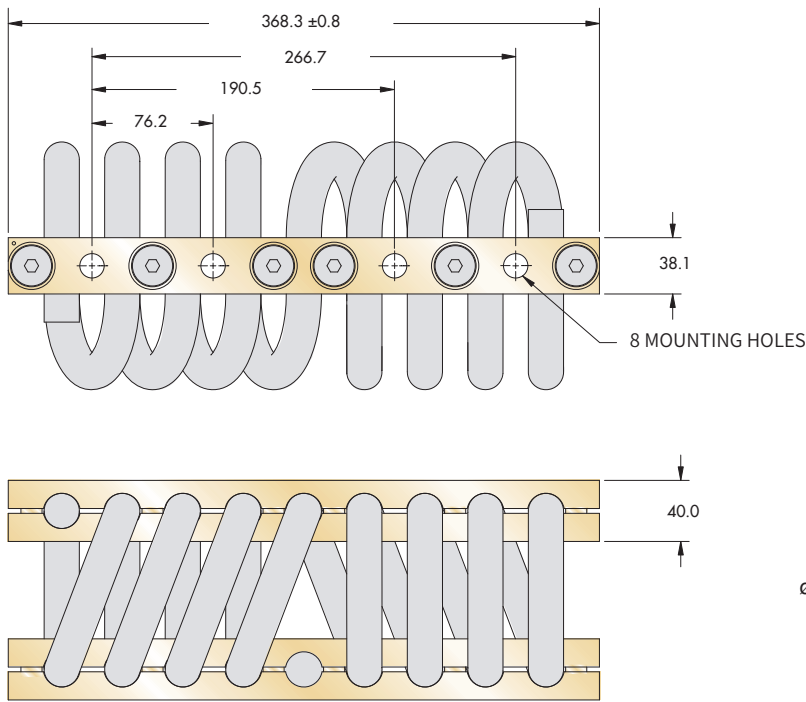

Note: Dimensions are in mm /
Tolerances are ±0.25mm

Model	Height ("H") mm	Width (Ref) mm	Unit Weight Kg	Mounting Options	Thru mm	Thread mm	C'Sink Metric
WR28-200	133	140	8.40	C, D	Ø13.5 ^{+0.13} -0.38	M12 X 1.75	90°
WR28-400	152	165	9.53	A, B, C, D, E, S			
WR28-600	159	178	9.90				
WR28-800	191	210	11.50				
WR28-900	216	235	12.70				
WR28-950	216	286	13.90				

Ordering Example

WR28 - 400 - 8 D H M

- Add "M" for Metric
- Threaded Hole Options
*[] - Tapped
[H] - Helical Insert, Free Running
[L] - Helical Insert, Self Locking
- Mounting Options See chart
- Number of Loops 8 (Reduced Number of Loops Available)
- Isolator Size See Sizing Table

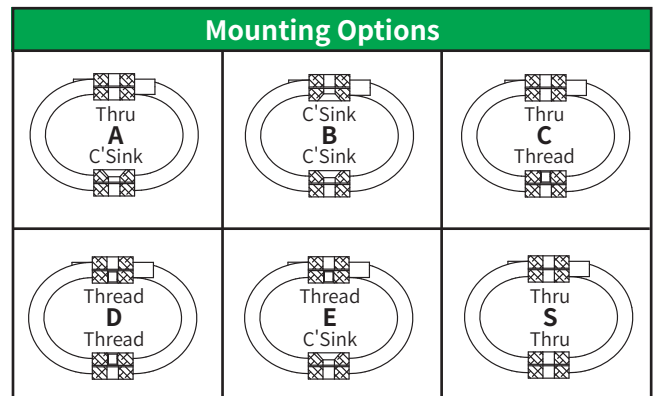

*Standard characteristics. Delivery time may be postponed for non-standard products.

- Maximum recommended torque for standard threaded insert is 100 Nm.
- Operating Temperature Range: -100°C~260°C

Static Load vs Deflection

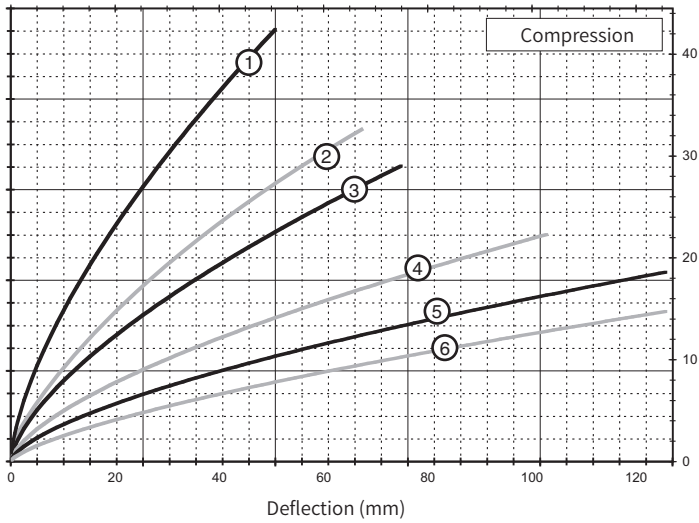

Compression

Curve	Model	Max. Static Load kN	Max. Deflection mm	Kv (Vibration) kN/m	Ks (Shock) kN/m
1	WR28-200-08	12.28	50.8	2 362	1 010
2	WR28-400-08	9.43	67.3	1 513	585
3	WR28-600-08	8.45	74.9	1 270	469
4	WR28-800-08	6.54	102.9	800	263
5	WR28-900-08	5.43	125.7	585	180
6	WR28-950-08	3.74	125.7	377	138

WR

45° Compression / Roll

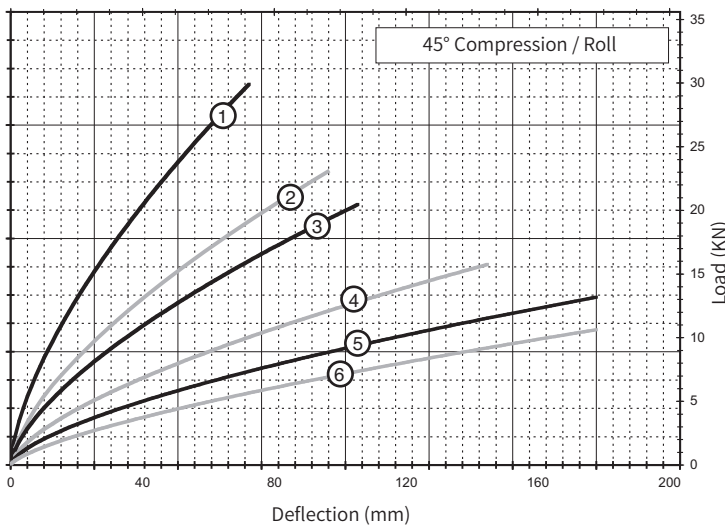

Curve	Model	Max. Static Load kN	Max. Deflection mm	Kv (Vibration) kN/m	Ks (Shock) kN/m
1	WR28-200-08	8.72	72.4	1 348	503
2	WR28-400-08	6.67	96.5	860	289
3	WR28-600-08	6.01	105.4	718	235
4	WR28-800-08	4.45	144.8	448	131
5	WR28-900-08	3.25	177.8	327	89
6	WR28-950-08	2.11	177.8	212	70

Shear/Roll

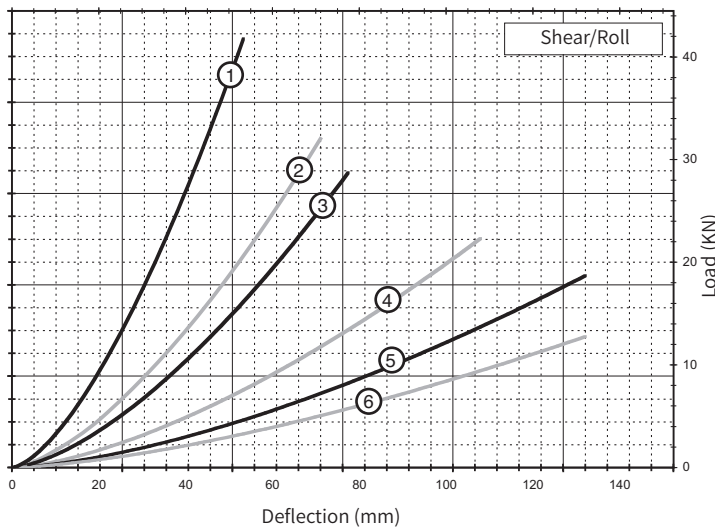

Curve	Model	Max. Static Load kN	Max. Deflection mm	Kv (Vibration) kN/m	Ks (Shock) kN/m
1	WR28-200-08	6.14	53.3	618	618
2	WR28-400-08	3.54	71.1	356	356
3	WR28-600-08	2.89	77.5	291	291
4	WR28-800-08	1.62	108.0	163	163
5	WR28-900-08	1.11	132.1	112	112
6	WR28-950-08	0.76	132.1	77	77

Note: Performance provided for full loop models with standard (302/304) stainless steel cable. Please consult EKD company for other options. Do not extrapolate curves.

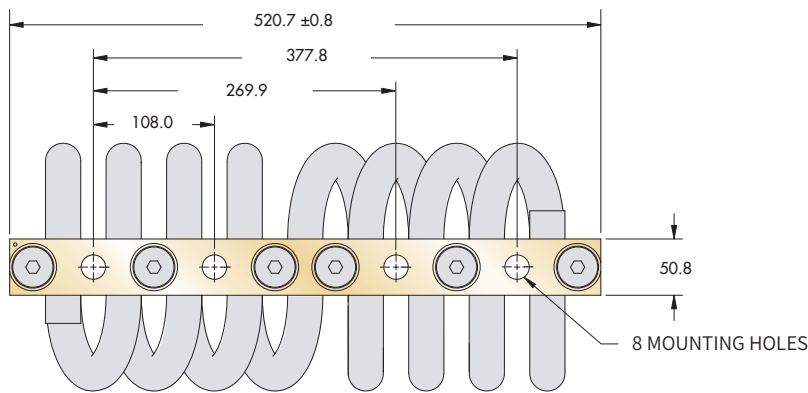

Note: Dimensions are in mm /
Tolerances are ±0.25mm

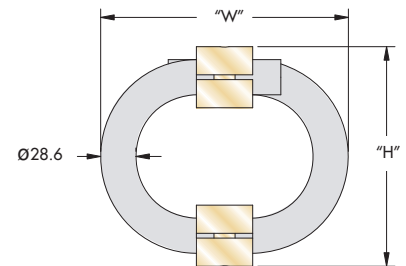
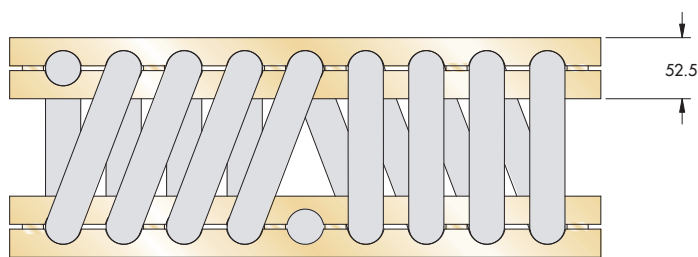

Model	Height ("H") mm	Width (Ref) mm	Unit Weight Kg	Mounting Options	Thru mm	Thread mm	C'Sink Metric
WR36-200	178	216	20.9	A, B, C, D, E, S	Ø19.8 +0.13 -0.38	M18 X 2.5	90°
WR36-400	216	241	24.0				
WR36-600	235	260	25.0				

Ordering Example

WR36 - 400 - 8 D H M

- WR36 - Isolator Size See Sizing Table
- 400 - Number of Loops 8 (Reduced Number of Loops Available)
- 8 - Mounting Options See chart
- D - Threaded Hole Options
 - *[] - Tapped
 - [H] - Helical Insert, Free Running
 - [L] - Helical Insert, Self Locking
- H - Add "M" for Metric

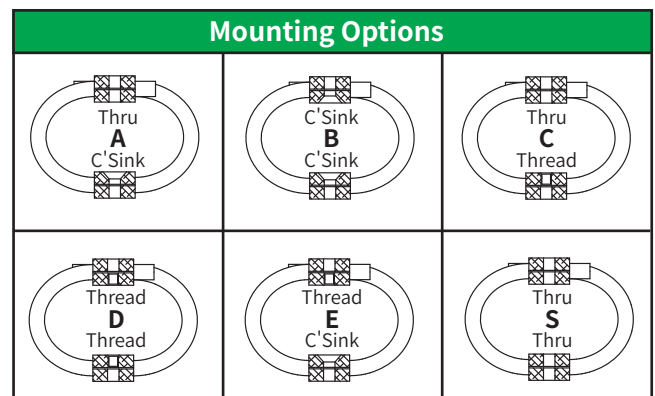

*Standard characteristics. Delivery time may be postponed for non-standard products.

- Maximum recommended torque for standard threaded insert is 300 Nm.
- Operating Temperature Range: -100°C~260°C

Static Load vs Deflection

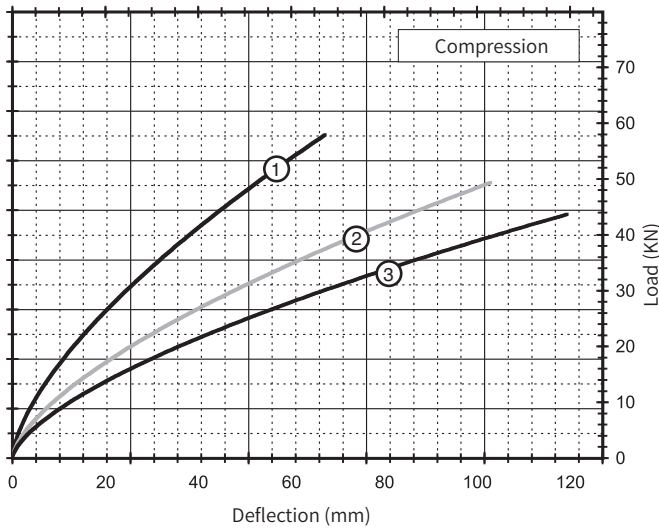

Compression

Curve	Model	Max. Static Load KN	Max. Deflection mm	Kv (Vibration) kN/m	Ks (Shock) kN/m
1	WR36-200-08	16.86	67.3	2 706	1 044
2	WR36-400-08	14.50	102.9	1 774	583
3	WR36-600-08	12.77	119.4	1 415	445

WR

45° Compression / Roll

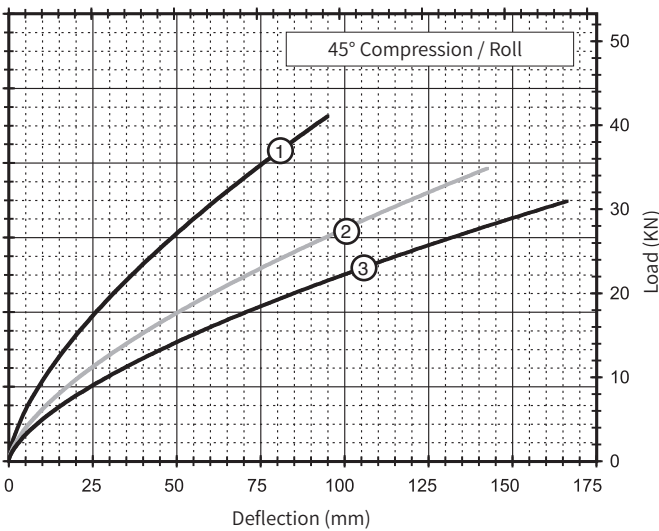

Curve	Model	Max. Static Load KN	Max. Deflection mm	Kv (Vibration) kN/m	Ks (Shock) kN/m
1	WR36-200-08	11.97	96.5	1 541	518
2	WR36-400-08	9.88	144.8	993	292
3	WR36-600-08	7.96	168.9	799	222

Shear/Roll

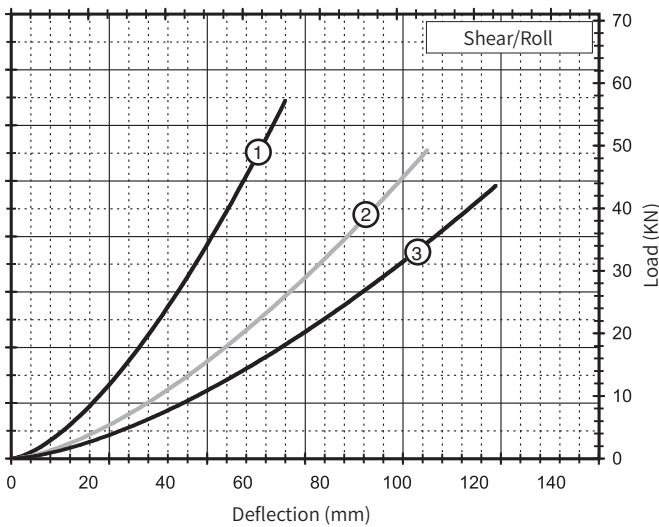

Curve	Model	Max. Static Load KN	Max. Deflection mm	Kv (Vibration) kN/m	Ks (Shock) kN/m
1	WR36-200-08	6.32	71.1	636	636
2	WR36-400-08	3.60	108.0	361	361
3	WR36-600-08	2.74	125.7	275	275

Note: Performance provided for full loop models with standard (302/304) stainless steel cable. Please consult EKD company for other options. Do not extrapolate curves.

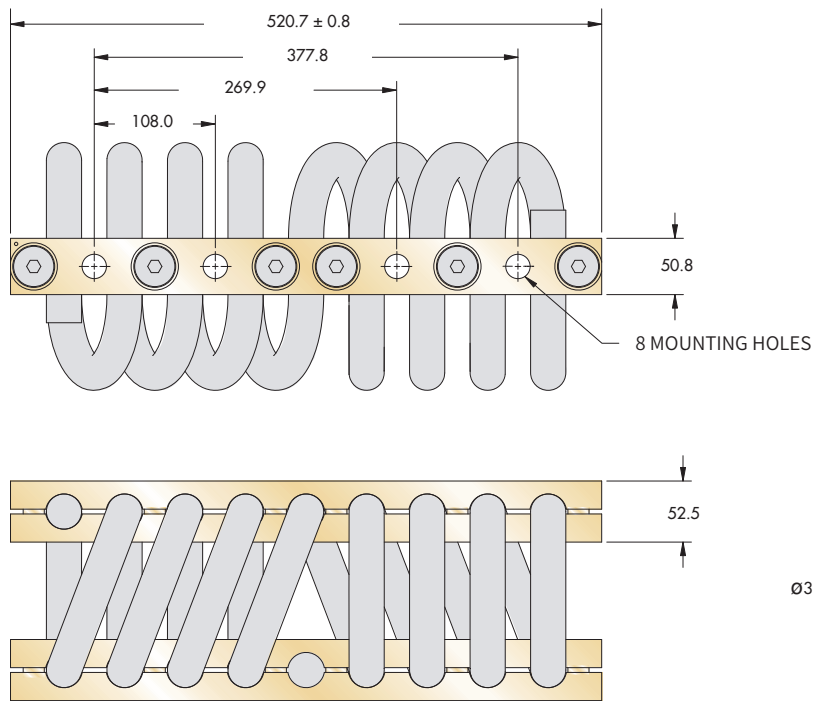

Note: Dimensions are in mm /
Tolerances are ±0.25mm



Model	Height ("H") mm	Width (Ref) mm	Unit Weight Kg	Mounting Options	Thru mm	Thread mm	C'Sink Metric
WR40-200	178	210	24.0	A, B, C, D, E, S	Ø19.8 +0.13 -0.38	M18 X 2.5	90°
WR40-400	216	248	27.2				

Ordering Example

WR40 - 400 - 8 D H M

- WR40 - Isolator Size See Sizing Table
- 400 - Number of Loops 8 (Reduced Number of Loops Available)
- 8 - Mounting Options See chart
- D - Threaded Hole Options
 - [] - Tapped
 - [H] - Helical Insert, Free Running
 - [L] - Helical Insert, Self Locking
- H - Add "M" for Metric

Mounting Options

*Standard characteristics. Delivery time may be postponed for non-standard products.

- Maximum recommended torque for standard threaded insert is 300 Nm.
- Operating Temperature Range: -100°C~260°C

Static Load vs Deflection

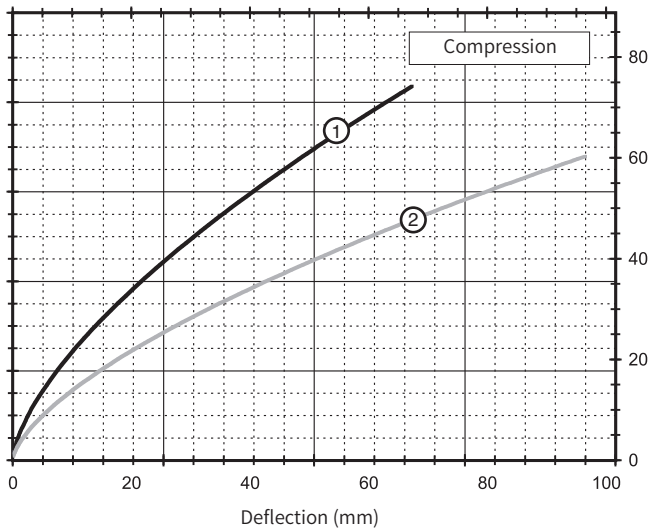

Compression

Curve	Model	Max. Static Load kN	Max. Deflection mm	Kv (Vibration) kN/m	Ks (Shock) kN/m
1	WR40-200-08	21.62	67.3	3 468	1 338
2	WR40-400-08	17.61	96.5	2 236	758

45° Compression / Roll

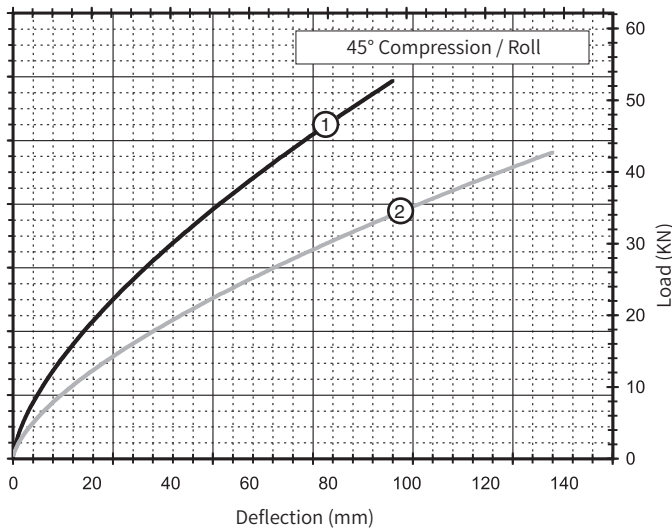

Curve	Model	Max. Static Load kN	Max. Deflection mm	Kv (Vibration) kN/m	Ks (Shock) kN/m
1	WR40-200-08	15.30	96.5	1 968	664
2	WR40-400-08	12.41	137.2	1 256	378

Shear/Roll

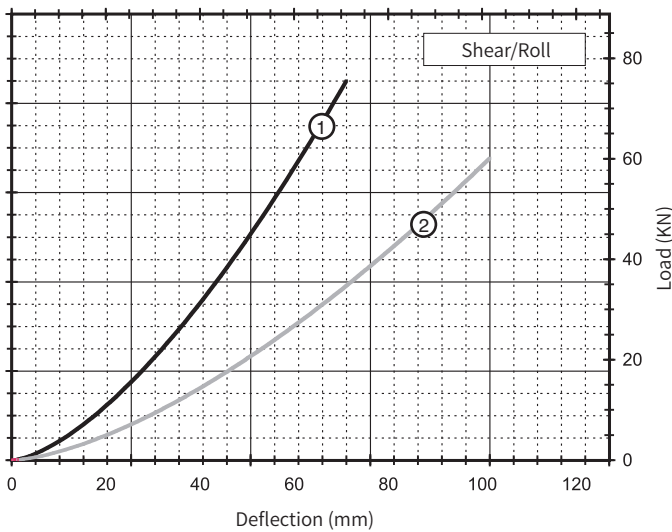

Curve	Model	Max. Static Load kN	Max. Deflection mm	Kv (Vibration) kN/m	Ks (Shock) kN/m
1	WR40-200-08	8.32	71.1	839	839
2	WR40-400-08	4.64	101.6	468	468

Note: Performance provided for full loop models with standard (302/304) stainless steel cable. Please consult EKD company for other options. Do not extrapolate curves.

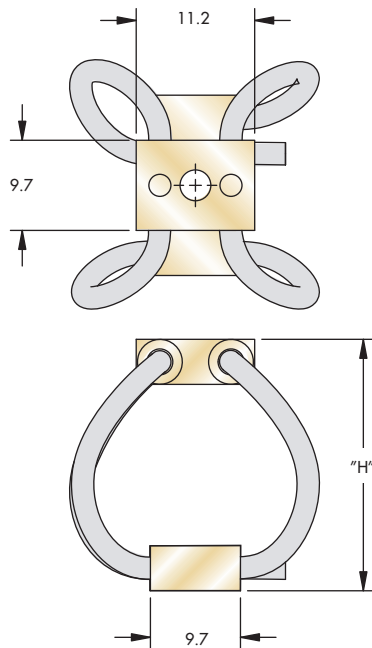

Note: Dimensions are in mm /
Tolerances are $\pm 0.25\text{mm}$

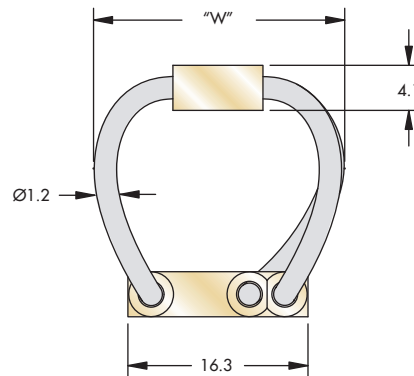

Model	Height ("H") mm	Width (Ref) "W" mm	Unit Weight Kg	Mounting Options	Thru mm	Thread mm	C'Sink Metric
CR1-100	17	19	3.1	A, B, C, D, E, S	Ø3.30	M3 X 0.5	90°
CR1-200	19	20	3.1				
CR1-300	23	23	3.4				
CR1-400	26	26	3.4				

Ordering Example

CR1 - 400 - D M

- CR1 - Isolator Size See Sizing Table
- 400 - Isolator Size See Sizing Table
- D - Mounting Options See chart
- M - Add "M" for Metric

Mounting Options

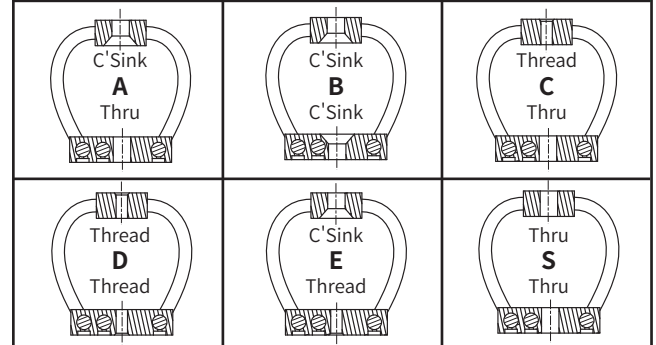

*Standard characteristics. Delivery time may be postponed for non-standard products.

- Maximum recommended torque for tapped aluminum bar is 1.2 Nm.
- Wire Rope Material: Stranded 300 series stainless steel
- Operating Temperature Range: $-100^{\circ}\text{C} \sim 260^{\circ}\text{C}$

Static Load vs Deflection

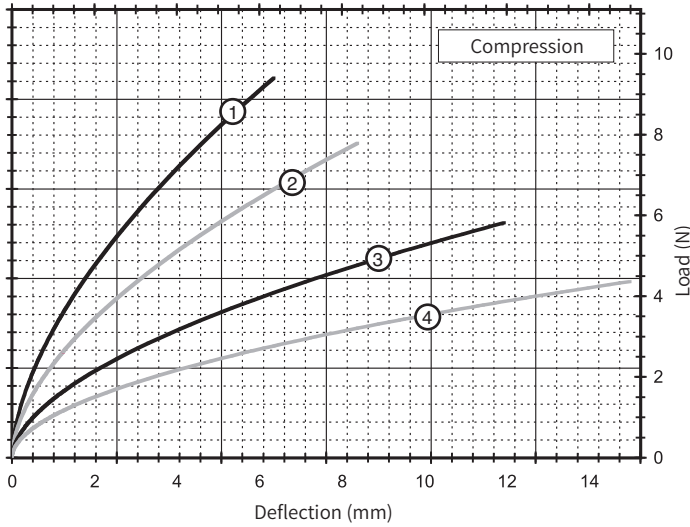

Compression

Curve	Model	Max. Static Load N	Max. Deflection mm	Kv (Vibration) kN/m	Ks (Shock) kN/m
1	CR1-100	3.3	6.4	3.9	1.9
2	CR1-200	2.4	8.4	2.8	1.2
3	CR1-300	1.8	11.9	1.75	0.61
4	CR1-400	1.3	15.0	1.31	0.39

CR

45° Compression / Roll

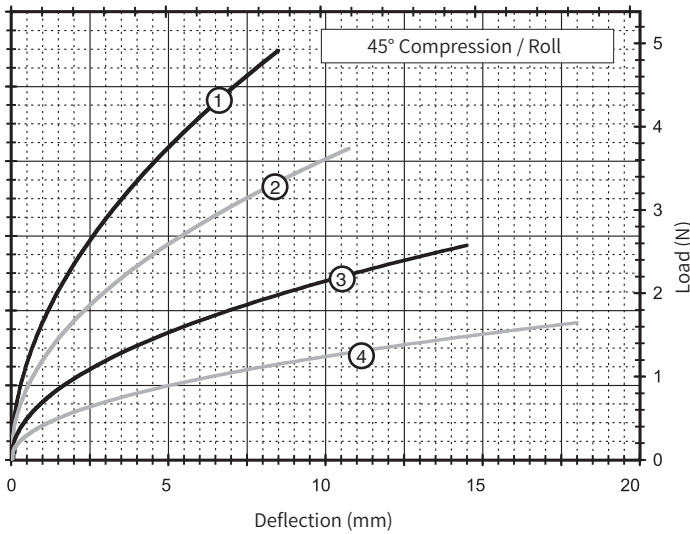

Curve	Model	Max. Static Load N	Max. Deflection mm	Kv (Vibration) kN/m	Ks (Shock) kN/m
1	CR1-100	1.6	8.6	2.1	0.79
2	CR1-200	1.1	10.9	1.5	0.44
3	CR1-300	0.76	14.7	0.88	0.26
4	CR1-400	0.49	18.3	0.53	0.12

Shear/Roll

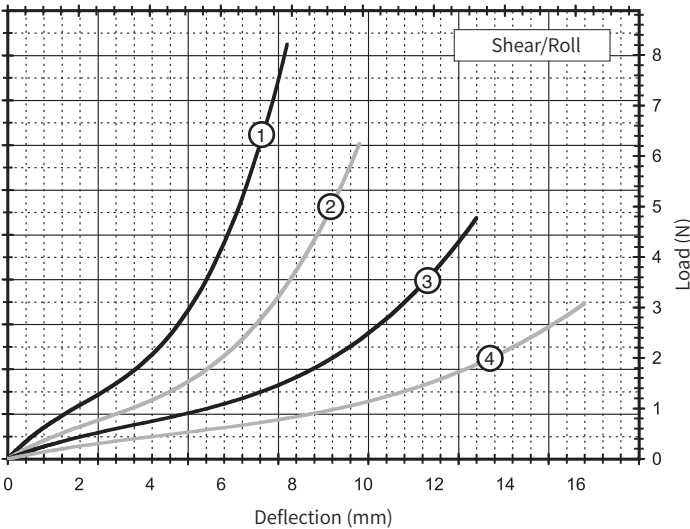

Curve	Model	Max. Static Load N	Max. Deflection mm	Kv (Vibration) kN/m	Ks (Shock) kN/m
1	CR1-100	1.1	7.9	0.70	0.70
2	CR1-200	0.89	9.9	0.44	0.44
3	CR1-300	0.71	13.2	0.26	0.26
4	CR1-400	0.53	16.3	0.13	0.13

Note: Performance provided for full loop models with standard (302/304) stainless steel cable. Please consult EKD company for other options. Do not extrapolate curves.

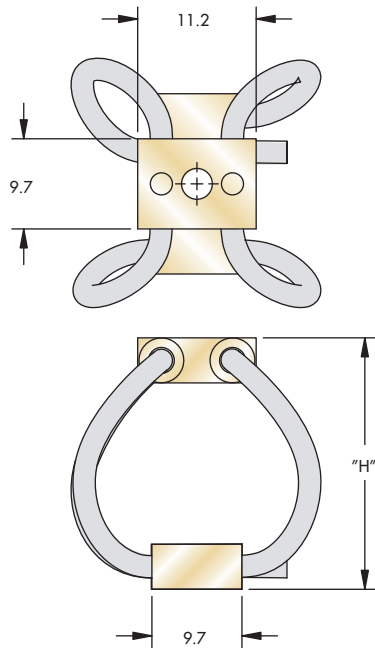

Note: Dimensions are in mm /
Tolerances are ±0.25mm

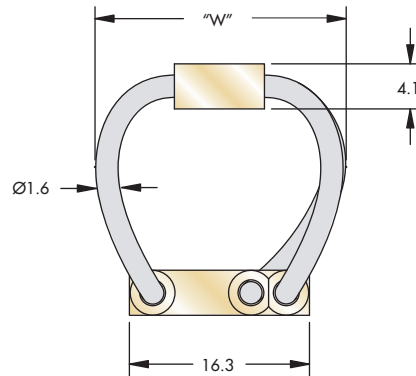

Model	Height ("H") mm	Width (Ref) "W" mm	Unit Weight Kg	Mounting Options	Thru mm	Thread mm	C'Sink Metric
CR2-100	16	± 1.52	20	A, B, C, D, E, S	Ø3.30	M3 X 0.5	90°
CR2-200	19		21				
CR2-300	23		24				
CR2-400	27		27				

Ordering Example

CR2 - 400 - D M

- Add "M" for Metric
- Mounting Options See chart
- Isolator Size See Sizing Table

Mounting Options

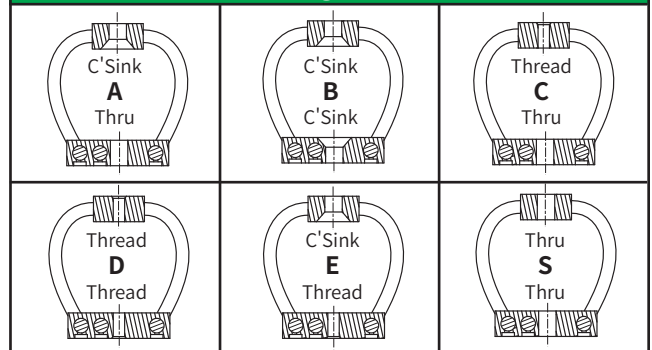

*Standard characteristics. Delivery time may be postponed for non-standard products.

- Maximum recommended torque for tapped aluminum bar is 1.2 Nm.
- Wire Rope Material: Stranded 300 series stainless steel
- Operating Temperature Range: -100°C~260°C

Static Load vs Deflection

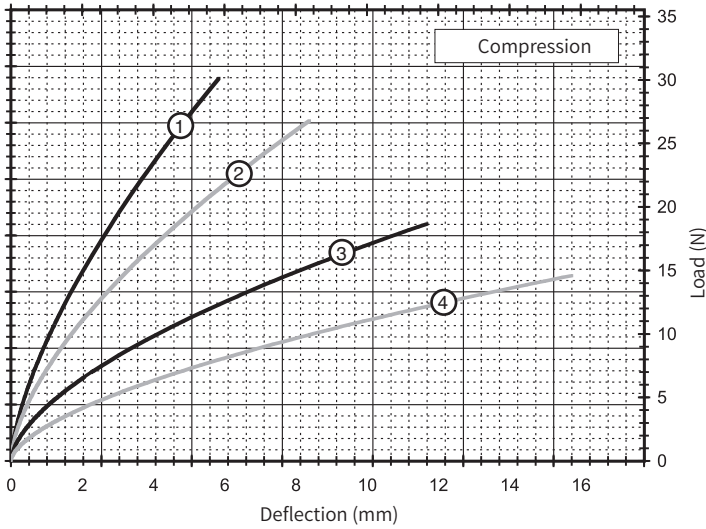

Compression

Curve	Model	Max. Static Load N	Max. Deflection mm	Kv (Vibration) kN/m	Ks (Shock) kN/m
1	CR2-100	12	5.8	11	6.1
2	CR2-200	9.3	8.4	8.8	4.0
3	CR2-300	6.7	11.7	5.3	1.9
4	CR2-400	4.9	15.7	3.5	1.2

45° Compression / Roll

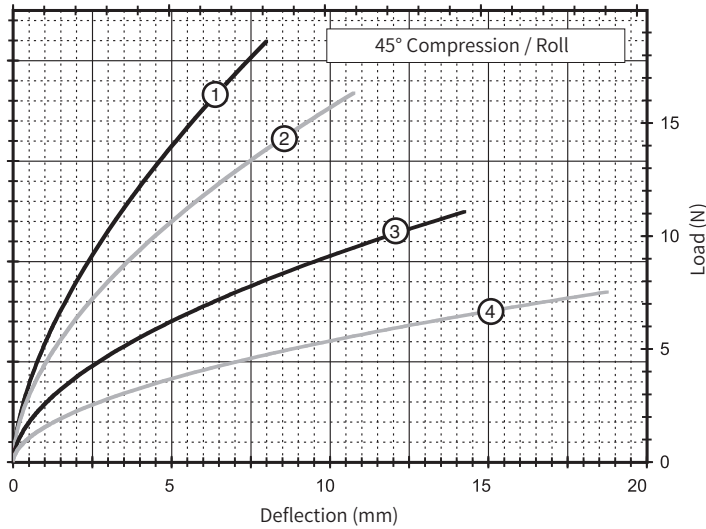

Curve	Model	Max. Static Load N	Max. Deflection mm	Kv (Vibration) kN/m	Ks (Shock) kN/m
1	CR2-100	5.8	8.1	6.1	2.8
2	CR2-200	4.9	10.9	5.3	1.9
3	CR2-300	3.3	14.5	3.2	1.0
4	CR2-400	2.2	19.1	1.9	0.51

Shear/Roll

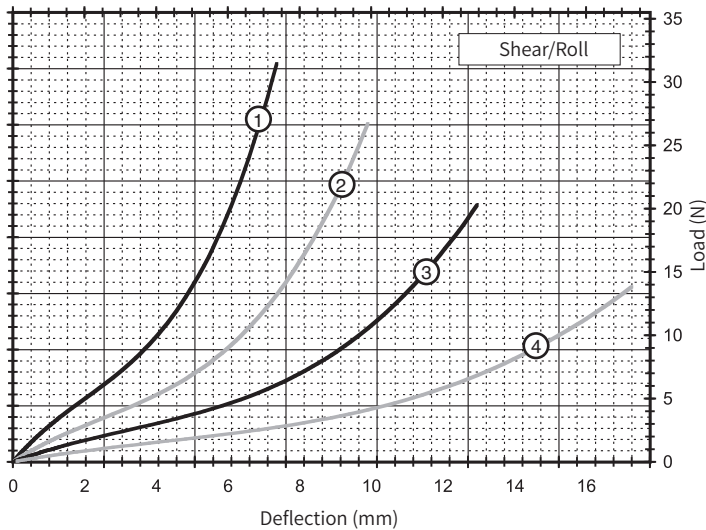

Curve	Model	Max. Static Load N	Max. Deflection mm	Kv (Vibration) kN/m	Ks (Shock) kN/m
1	CR2-100	5.6	7.4	3.0	3.0
2	CR2-200	4.0	9.9	1.8	1.8
3	CR2-300	2.9	13.0	1.1	1.1
4	CR2-400	2.0	17.3	0.53	0.53

Note: Performance provided for full loop models with standard (302/304) stainless steel cable. Please consult EKD company for other options. Do not extrapolate curves.

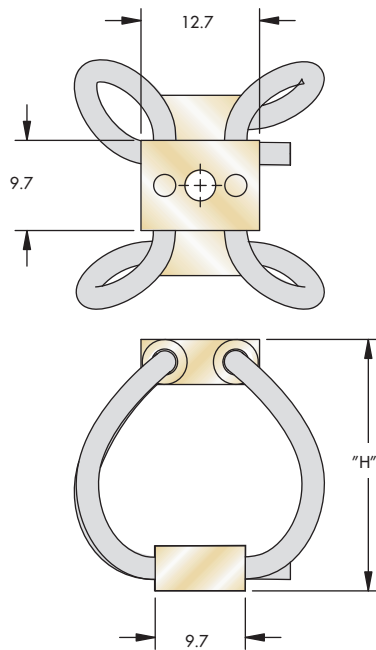

Note: Dimensions are in mm /
Tolerances are ±0.25mm

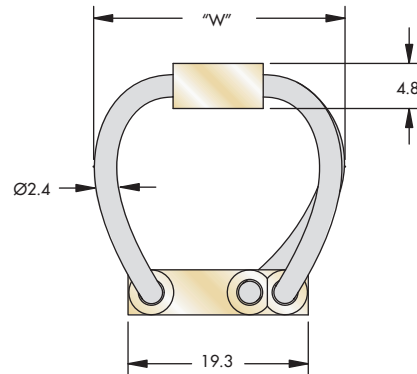

Model	Height ("H") mm	Width (Ref) "W" mm	Unit Weight Kg	Mounting Options	Thru mm	Thread mm	C'Sink Metric
CR3-100	19	22	5.7	A, B, C, D, E, S	Ø3.30	M3 X 0.5	90°
CR3-200	23	24	6.2				
CR3-300	27	27	6.8				
CR3-400	33	30	7.4				

Ordering Example

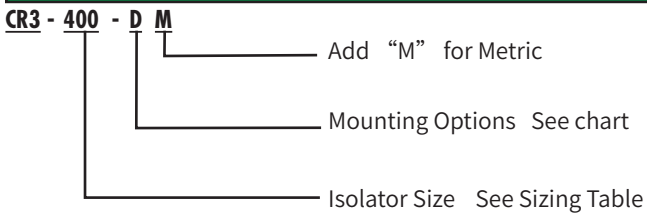

Mounting Options

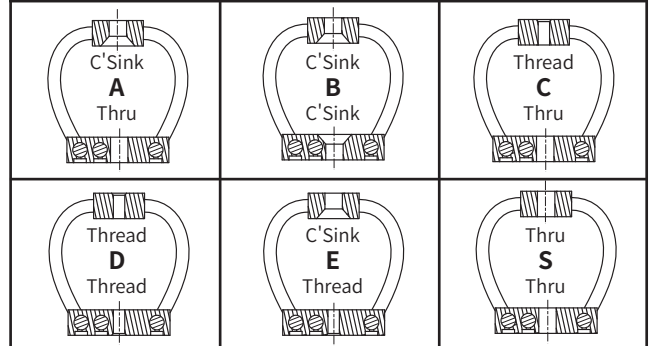

*Standard characteristics. Delivery time may be postponed for non-standard products.

- Maximum recommended torque for tapped aluminum bar is 1.5 Nm.
- Wire Rope Material: Stranded 300 series stainless steel
- Operating Temperature Range: -100°C~260°C

Static Load vs Deflection

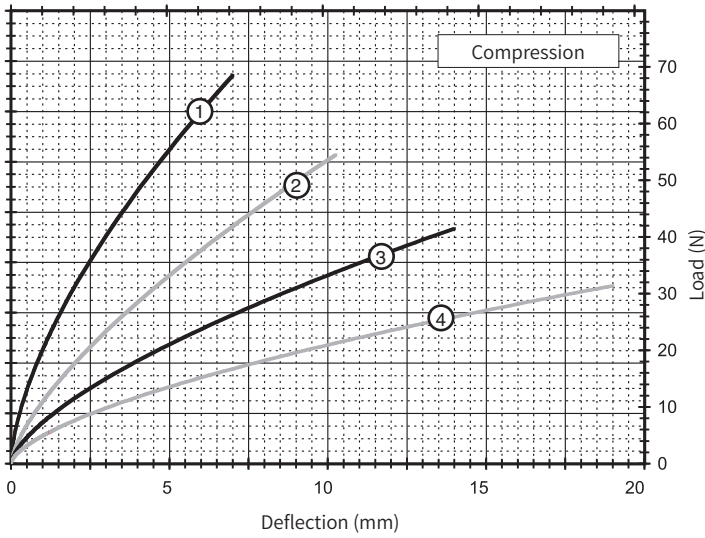

Compression

Curve	Model	Max. Static Load N	Max. Deflection mm	Kv (Vibration) kN/m	Ks (Shock) kN/m
1	CR3-100	29	7.1	24	12
2	CR3-200	22	10.4	12	6.1
3	CR3-300	18	14.2	8.4	3.5
4	CR3-400	11	19.3	5.8	1.9

CR

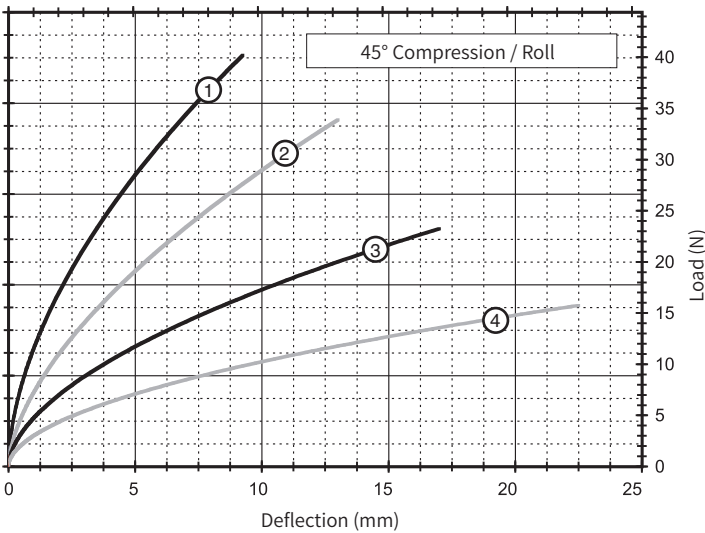

45° Compression / Roll

Curve	Model	Max. Static Load N	Max. Deflection mm	Kv (Vibration) kN/m	Ks (Shock) kN/m
1	CR3-100	12	9.4	14	5.3
2	CR3-200	10	13.2	8.8	3.2
3	CR3-300	6.7	17.3	5.8	1.8
4	CR3-400	4.4	22.9	3.5	0.91

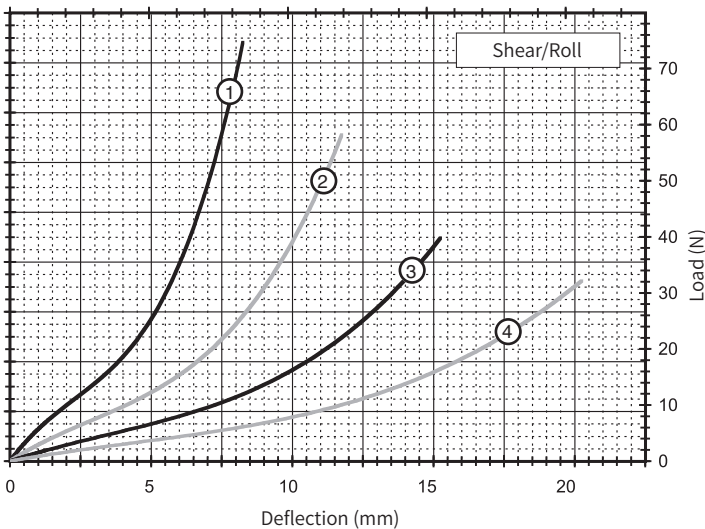

Shear/Roll

Curve	Model	Max. Static Load N	Max. Deflection mm	Kv (Vibration) kN/m	Ks (Shock) kN/m
1	CR3-100	12	8.4	6.1	6.1
2	CR3-200	8.5	11.9	3.5	3.5
3	CR3-300	6.2	15.5	1.8	1.8
4	CR3-400	4.4	20.6	1.1	1.1

Note: Performance provided for full loop models with standard (302/304) stainless steel cable. Please consult EKD company for other options. Do not extrapolate curves.

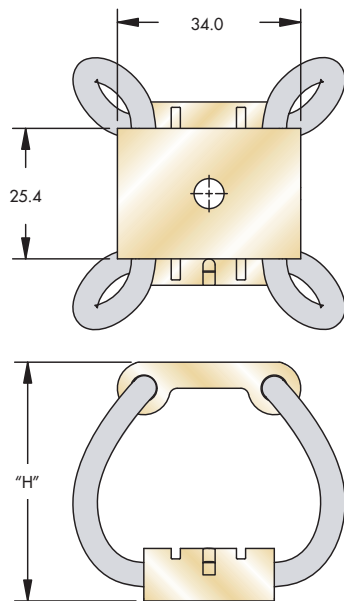

Note: Dimensions are in mm /
Tolerances are ±0.25mm

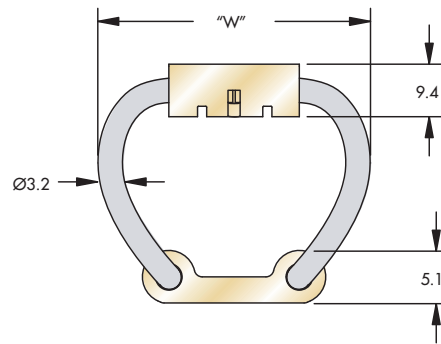

Model	Height ("H") mm	Width (Ref) "W" mm	Unit Weight Kg	Mounting Options	Thru mm	Thread mm	C'Sink Metric
CR4-100	42	47	40	A, B, C, D, E, S	Ø7.00	M6 X 1.0	90°
CR4-200	53	54	40				
CR4-300	60	59	43				
CR4-400	75	68	48				

Ordering Example

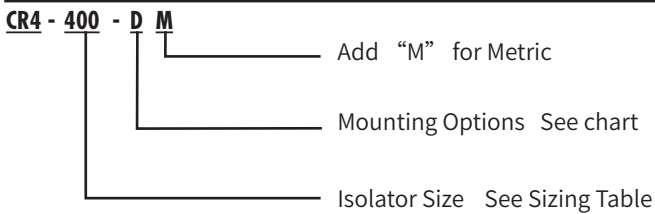

Mounting Options

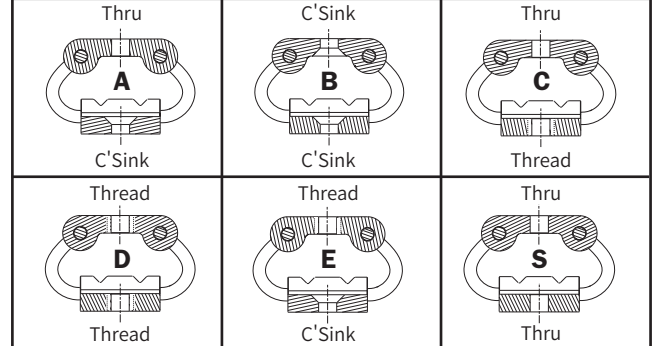

*Standard characteristics. Delivery time may be postponed for non-standard products.

- Maximum recommended torque for tapped aluminum bar is 7.5 Nm.
- Wire Rope Material: Stranded 300 series stainless steel
- Operating Temperature Range: -100°C~260°C

Static Load vs Deflection

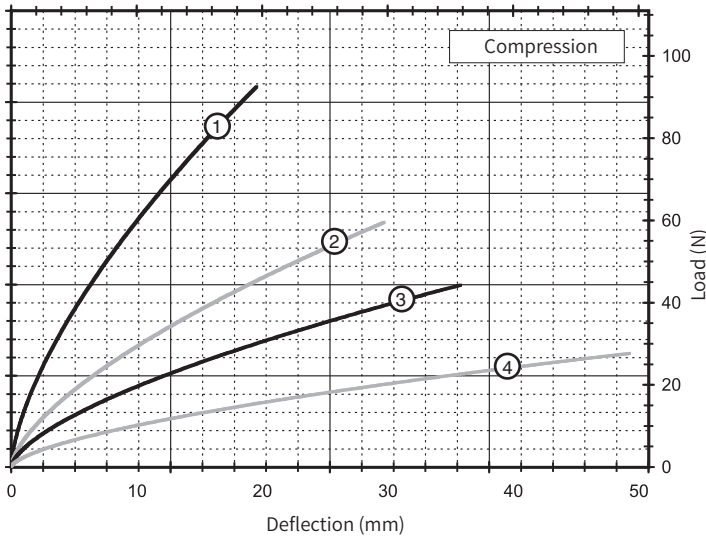

Compression

Curve	Model	Max. Static Load N	Max. Deflection mm	Kv (Vibration) kN/m	Ks (Shock) kN/m
1	CR4-100	24	19.6	12	5.8
2	CR4-200	18	29.7	6.0	2.5
3	CR4-300	13	35.8	4.4	1.6
4	CR4-400	6.7	49.3	2.2	0.70

CR

45° Compression / Roll

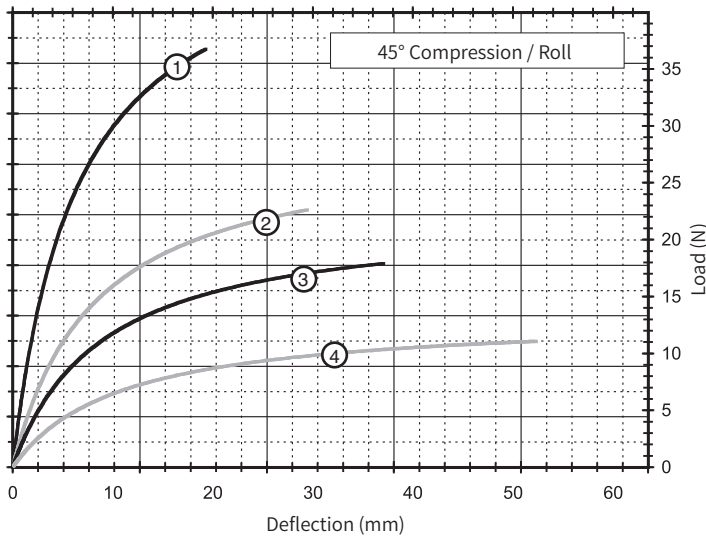

Curve	Model	Max. Static Load N	Max. Deflection mm	Kv (Vibration) kN/m	Ks (Shock) kN/m
1	CR4-100	11	19.3	6.4	2.8
2	CR4-200	6.7	29.5	3.1	1.1
3	CR4-300	5.3	37.1	2.2	0.70
4	CR4-400	3.6	52.3	1.1	0.35

Shear/Roll

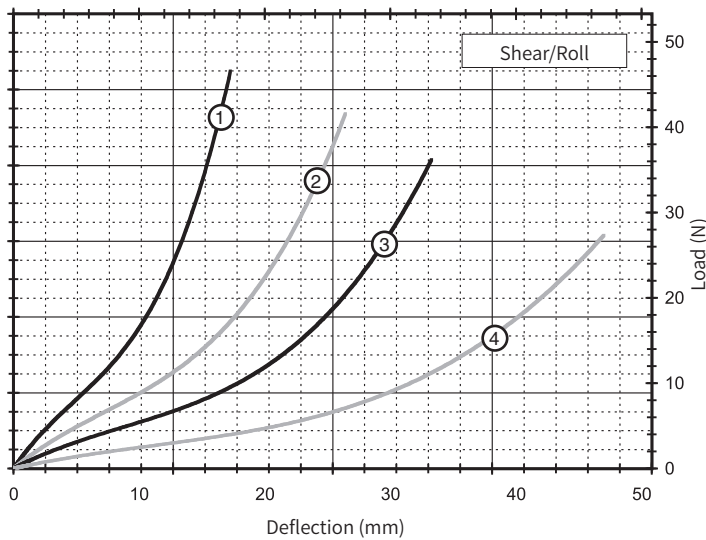

Curve	Model	Max. Static Load N	Max. Deflection mm	Kv (Vibration) kN/m	Ks (Shock) kN/m
1	CR4-100	8.5	17.3	1.9	1.9
2	CR4-200	7.1	26.4	1.1	1.1
3	CR4-300	5.3	33.3	0.70	0.70
4	CR4-400	3.3	47.0	0.35	0.35

Note: Performance provided for full loop models with standard (302/304) stainless steel cable. Please consult EKD company for other options. Do not extrapolate curves.

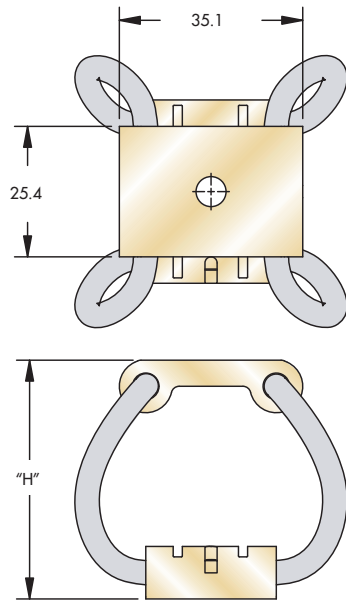

Note: Dimensions are in mm /
Tolerances are ±0.25mm

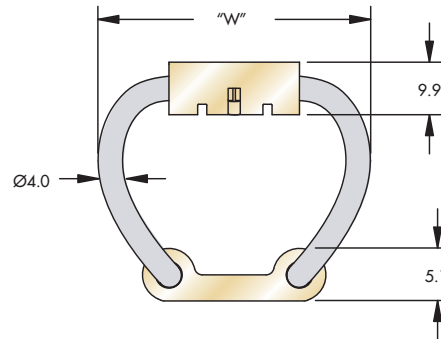

Model	Height ("H") mm	Width (Ref) "W" mm	Unit Weight Kg	Mounting Options	Thru mm	Thread mm	C'Sink Metric
CR5-100	41	48	45	A, B, C, D, E, S	Ø7.00	M6 X 1.0	90°
CR5-200	53	54	48				
CR5-300	60	59	51				
CR5-400	76	67	57				

Ordering Example

CR5 - 400 - D M

- CR5 - Isolator Size See Sizing Table
- 400 - Isolator Size See Sizing Table
- D - Mounting Options See chart
- M - Add "M" for Metric

Mounting Options

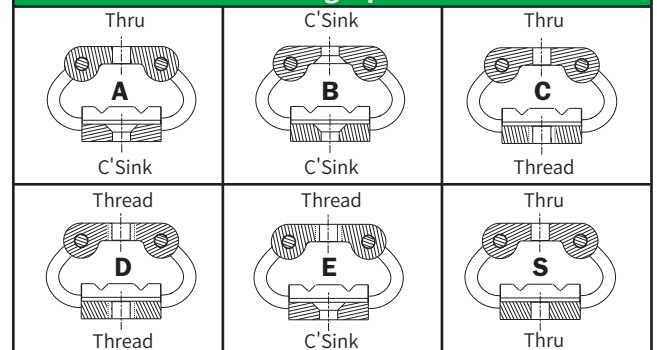

*Standard characteristics. Delivery time may be postponed for non-standard products.

- Maximum recommended torque for tapped aluminum bar is 7.5 Nm.
- Wire Rope Material: Stranded 300 series stainless steel
- Operating Temperature Range: -100°C~260°C

Static Load vs Deflection

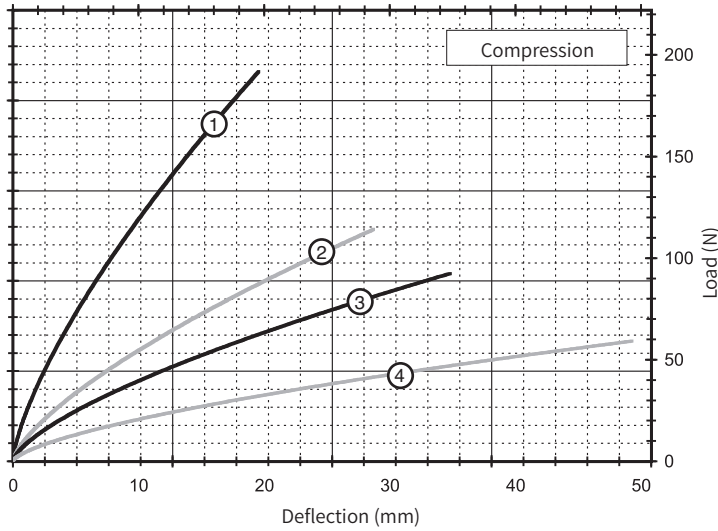

Compression

Curve	Model	Max. Static Load N	Max. Deflection mm	Kv (Vibration) kN/m	Ks (Shock) kN/m
1	CR5-100	80	19.6	22	11
2	CR5-200	38	28.7	11	4.4
3	CR5-300	27	34.8	7.9	3.2
4	CR5-400	16	49.3	4.4	1.4

CR

45° Compression / Roll

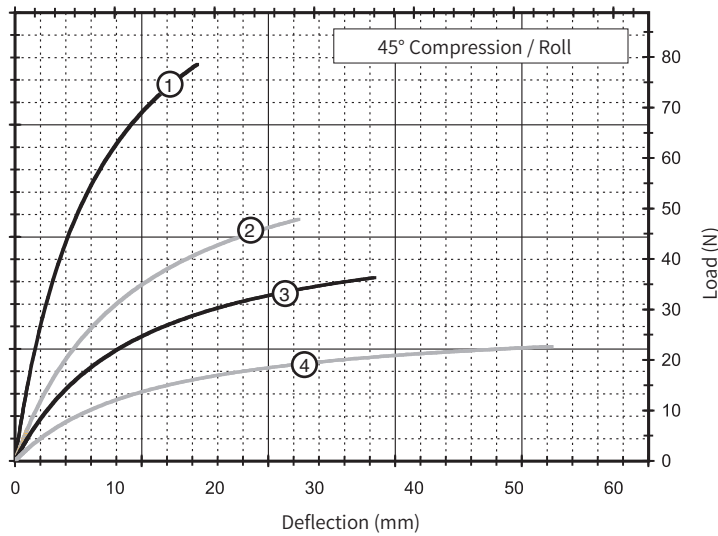

Curve	Model	Max. Static Load N	Max. Deflection mm	Kv (Vibration) kN/m	Ks (Shock) kN/m
1	CR5-100	24	18.3	12	6.1
2	CR5-200	13	28.4	5.3	2.3
3	CR5-300	11	36.1	3.6	1.4
4	CR5-400	6.7	53.8	1.9	0.70

Shear/Roll

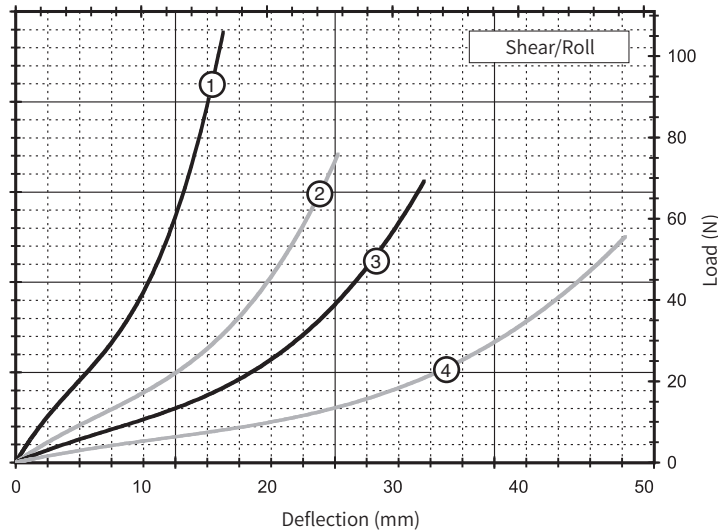

Curve	Model	Max. Static Load N	Max. Deflection mm	Kv (Vibration) kN/m	Ks (Shock) kN/m
1	CR5-100	20	16.5	4.4	4.4
2	CR5-200	13	25.7	2.1	2.1
3	CR5-300	11	32.5	1.4	1.4
4	CR5-400	6.7	48.5	0.70	0.70

Note: Performance provided for full loop models with standard (302/304) stainless steel cable. Please consult EKD company for other options. Do not extrapolate curves.

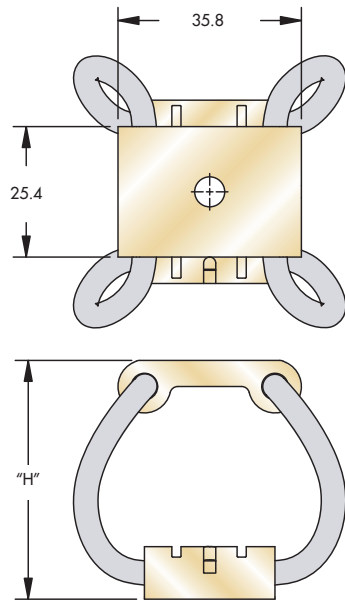

Note: Dimensions are in mm /
Tolerances are ±0.25mm

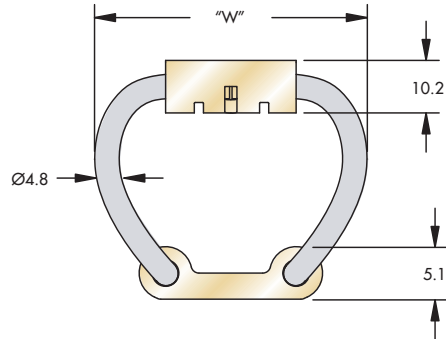

Model	Height ("H") mm	Width (Ref) "W" mm	Unit Weight Kg	Mounting Options	Thru mm	Thread mm	C'Sink Metric	
CR6-100	47	± 1.52	54	A, B, C, D, E, S	Ø7.00	M6 X 1.0	90°	
CR6-200	55		59					62
CR6-300	64		64					65
CR6-400	79		73					74

Ordering Example

CR6 - 400 - D M

- CR6 - Isolator Size See Sizing Table
- 400 - Isolator Size See Sizing Table
- D - Mounting Options See chart
- M - Add "M" for Metric

Mounting Options

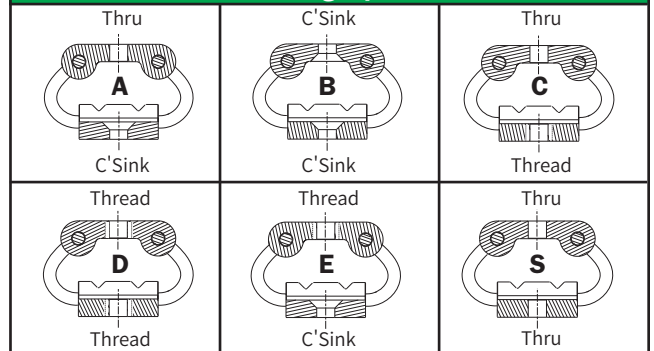

*Standard characteristics. Delivery time may be postponed for non-standard products.

- Maximum recommended torque for tapped aluminum bar is 7.5 Nm.
- Wire Rope Material: Stranded 300 series stainless steel
- Operating Temperature Range: -100°C~260°C



Static Load vs Deflection

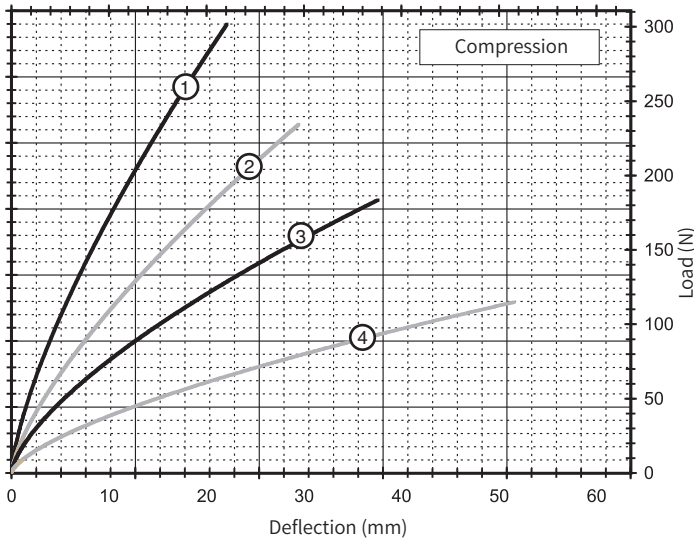

Compression

Curve	Model	Max. Static Load N	Max. Deflection mm	Kv (Vibration) kN/m	Ks (Shock) kN/m
1	CR6-100	142	22.1	32	16
2	CR6-200	93	29.5	20	9.6
3	CR6-300	67	37.6	15	5.3
4	CR6-400	36	51.6	7.9	2.6

45° Compression / Roll

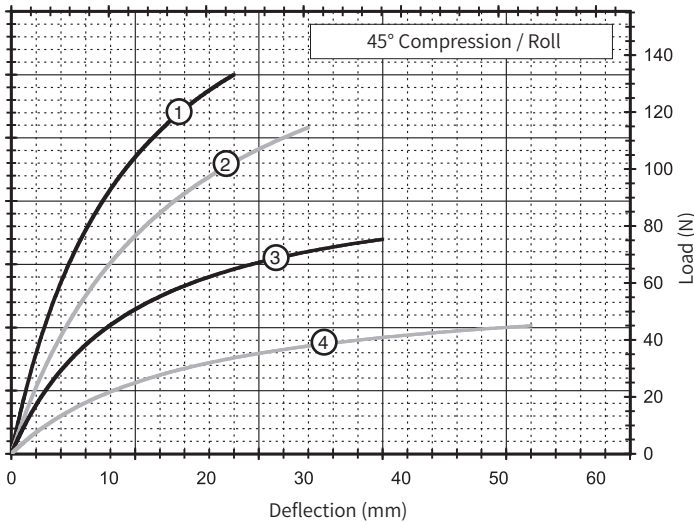

Curve	Model	Max. Static Load N	Max. Deflection mm	Kv (Vibration) kN/m	Ks (Shock) kN/m
1	CR6-100	40	22.9	16	7.9
2	CR6-200	33	30.5	9.6	5.3
3	CR6-300	22	38.1	7.9	2.8
4	CR6-400	13	53.3	3.5	1.2

Shear/Roll

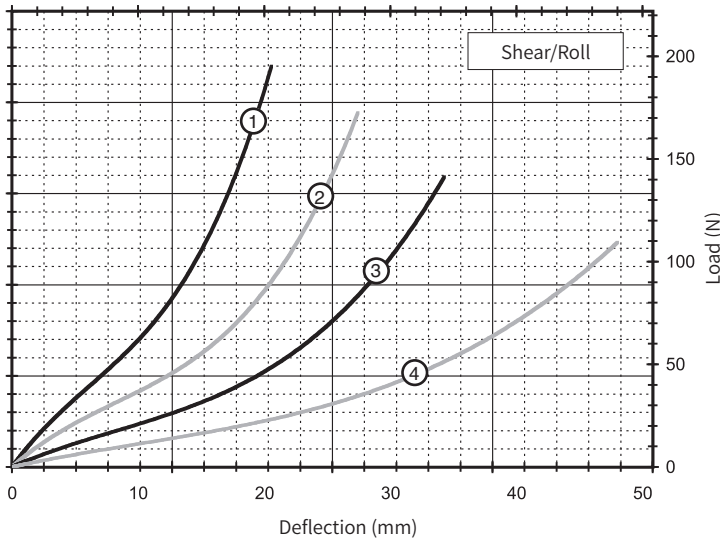

Curve	Model	Max. Static Load N	Max. Deflection mm	Kv (Vibration) kN/m	Ks (Shock) kN/m
1	CR6-100	40	20.6	7.9	7.9
2	CR6-200	31	27.4	4.4	4.4
3	CR6-300	22	34.3	2.6	2.6
4	CR6-400	16	48.0	1.6	1.6

Note: Performance provided for full loop models with standard (302/304) stainless steel cable. Please consult EKD company for other options. Do not extrapolate curves.

ADONI TECH

SLU- W- 39

Addl MIDC Kodoli,

Satara 415004

adonitech@gmail.com

<http://www.adonitech.co.in>

LOCAL REPRESENTATIVE